

DIXIE CHOPPER

The World's Fastest Lawn Mower

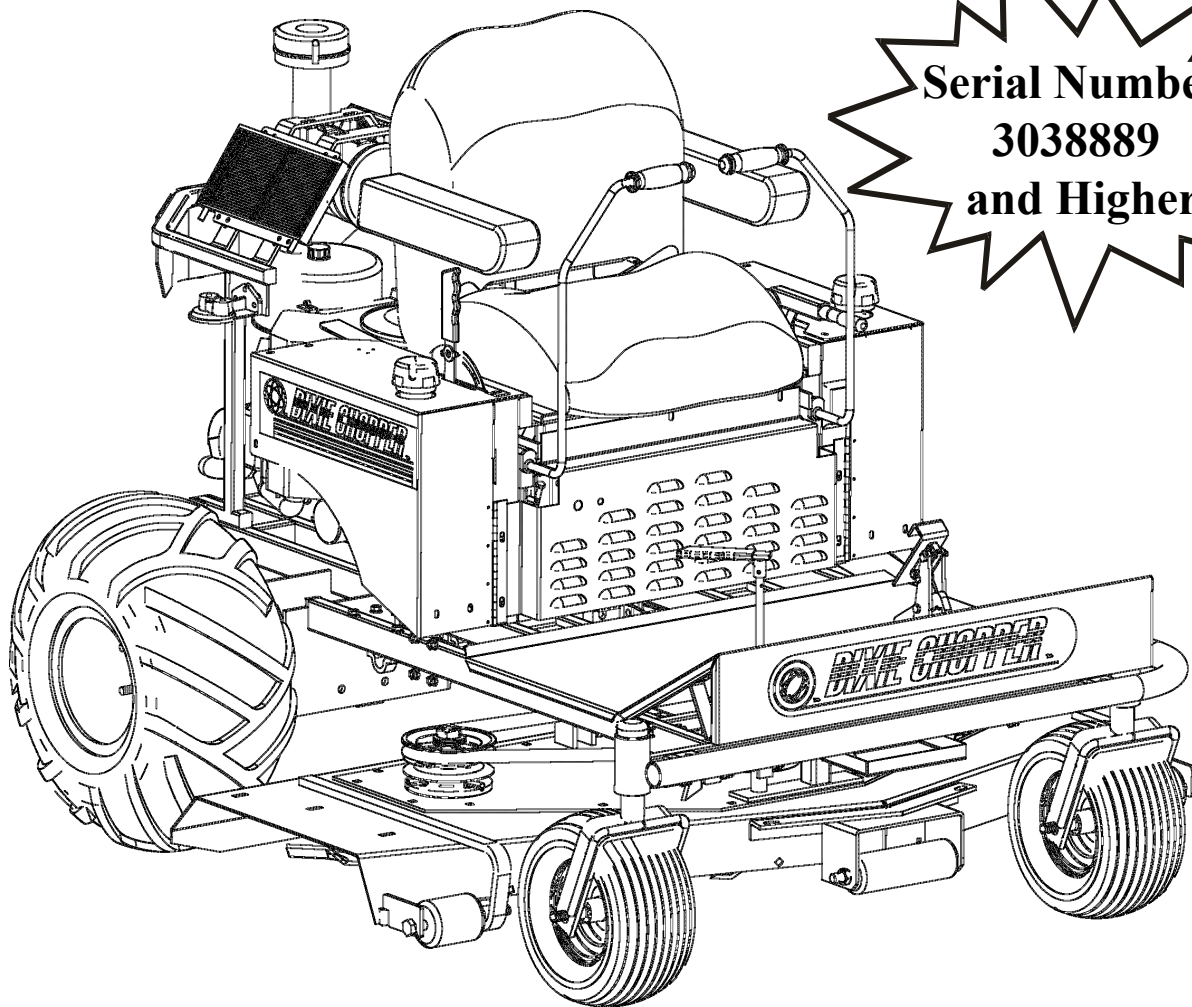

**Serial Numbers
3038889
and Higher**

Model # _____

Engine Model # _____

Serial # _____

Engine Serial # _____

Date Purchased _____

Engine Spec. # _____

XXW & XT-72 PARTS MANUAL

DIXIE CHOPPER

Congratulations on your purchase of a **DIXIE CHOPPER** lawn mower. We believe you have exercised excellent judgement, and are most appreciative of your patronage.

**Your DIXIE CHOPPER Dealer is your #1 SOURCE for
DIXIE CHOPPER parts and service !**

Please call or visit your nearest authorized Dixie Chopper Dealer for additional service information.

AUTHORIZED DEALER

Let us know how you are getting along with your new CHOPPER!
www.dixiechopper.com

Dixie Chopper reserves the right to make changes or add improvements to its products at any time without incurring any obligation to make such changes to products previously manufactured. Neither Dixie Chopper, nor its dealers, accept responsibility for variations which may be evident in the actual specifications of its products and the statements and descriptions contained in this publication.

CONTENTS

Quick Reference Parts	1
Decals	2
Decal Placement	5
Frame	6
Wheels & Tires	11
Foot Pedal	12
Deck Lift System	13
OCDC	14
Deck	15
Hubs and Belts	17
Transmission Frame	19
Transmission & Drive	22
Wheel Motor	24
Hydraulic Hose Diagram	26
Fuel System	31
Throttle	33
Body	35
Brake	37
Center Hub	39
Engine POD	40
XXW4600 Engine Oil Routing	42
Engine 23Hp Kohler	43
Engine 28Hp EFI Kohler	44
Engine 30Hp Generac	45
Electrical Diagram 23Hp Kohler	49
Electrical Diagram 28Hp EFI Kohler	50
Electrical Diagram 30Hp Generac	51
Notes	52

DIXIE CHOPPER

XXW & XT MODEL QUICK REFERENCE PARTS

MODEL	XT2800	XXW4600	XT3000
Engine	Kohler 28Hp	Kohler 23Hp (2X)	Generac 30Hp
Deck	72"	72"	72"
Rear Tires	400055	400055	400055
Rear Rims	400054	400054	400054
Rear Tire & Rim	400042	400042	400042
Front Tire & Rim	400053	400053	400053
Front Rims	400071	400071	400071

Belts			
Engine-Transmission	9907B41	97345	9907B41
Engine-Deck	9907B85	68082	9907B85
Deck	68162	68162	68162
CenterHub - Engine 2		2 / 20256	

Filters			
Fuel Filter	97392	2 / 97392	97392
Nelson Air Filter Primary	25-083-01	25-083-01	
Nelson Air Filter Secondary	25-083-04	25-083-04	
Enginaire Filter Primary			600046
Enginaire Filter Secondary			600047
Amsoil Oil Filter	60119	2 / 60119	60119
Zinga-Hydro Filter	2 / 68140	2 / 68140	2 / 68140

Blades			
Standard	30227-72H	30227-72H	30227-72H
Heavy-Duty	30227-72N	30227-72N	30227-72H
Offset /72"	98007	98007	98007
Hard Face /72"	98125	98125	98125

VARIOUS PARTS ALL MODELS			
Fiber Washer	W-101		
Spindle Bearing	30218		
Deck Roller (Ctr)	30240-O		
Choke Control	20248		
Throttle Cable	68249		
Brake Cable	65246 (Left)	65247 (Right)	
Parking Brake Band	65244		
Fuel Cap	600035		
Control Lever Grip	20257		
Throttle Assembly	68250	68251	68250

DIXIE CHOPPER

DECALS



1



2



3



4



5



6



7

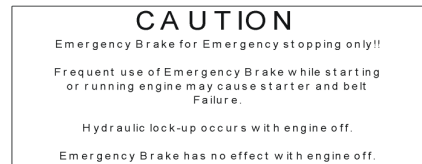

8

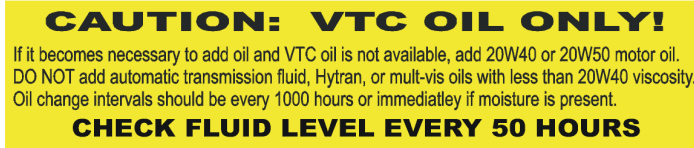

9



10

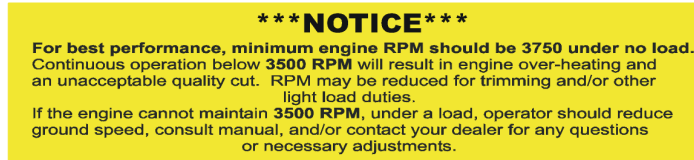

11



12



13



14



15

REF #	PART #	DESCRIPTION	QTY.
1	800025	XT2800 Front Panel	1
2	800024	XT3000 Front Panel	1
3	800007	XXW4600 Front Panel	1
4	65436	S'Burb'N Turb'N	1
5	65413	Patent Pending (T-Box)	1
6	800014	Ignition (Twin unit takes two.)	1
7	800015	Choke (Twin unit takes two.)	1
8	800018	Docu-Tube Decal (Back Of Seat)	1

REF #	PART #	DESCRIPTION	QTY.
9	97013	VTC Only (Oil Tank)	1
10	30591	Warranty Notice	1
11	97160	RPM Notice	1
12	30588	Hillside Danger	1
13	264000200210	VTC	1
14	30586	Tractor Buster (Rear Left Fender)	1
15	30590	USA Decal (Rear Left Fender)	1

DIXIE CHOPPER

DECALS (CONT'D)

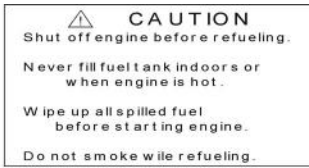

16

MODEL	ENG. TRANS.	ENG. DECK	DECK SPINDLE	CLUTCH DRIVE
42'	B-41	B-81	A-96	
50T-D	B-41	B-82	B-112	
50'	B-41	B-84	B-112	
60'	B-41	B-85	B-130	
CITY SLICKER				
72'	B-41	B-81	B-162	
TWIN				
72'	B-40	B-82	B-162	B-38

17

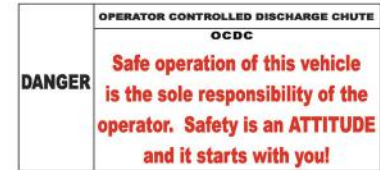

18



19



20



21

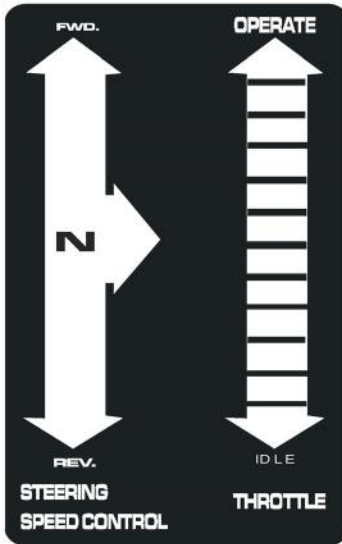

23



24



22

REF #	PART #	DESCRIPTION	QTY.
16	40118	Fuel Caution	2
17	800042	Belt Information	1
18	97072	OCDC Safety Decal	1
19	97514	Horn Warning	1
20	30229	Deck Danger Decal	2

REF #	PART #	DESCRIPTION	QTY.
21	30585	Fender Caution	1
22	65422	Belt Route Decal	1
23	63401	Throttle	1
24	63402	Brake & Steering	1

DIXIE CHOPPER

DECALS (CONT'D)



25



26

REF #	PART #	DESCRIPTION	QTY.
25	30573	Floor Pan Decal	2
	800033	Floor Pan Decal F/XT	2
26	30571	Fender Decal (Side Fender Left)	2
	800032	Fender Decal F/XT	2
27	800020	American Flag Decal (Side Fender Left)	1
28	800008	Hp + 1 Decal	1

REF #	PART #	DESCRIPTION	QTY.
29	800043	Throttle Start Decal	1
30	800022	Xtreme Mowchine	1
31	97097	Pod Decal	1
32	65437	72" Cut Decal	2
33	97008	Cross Member Decal	1

DIXIE CHOPPER

DECAL PLACEMENT

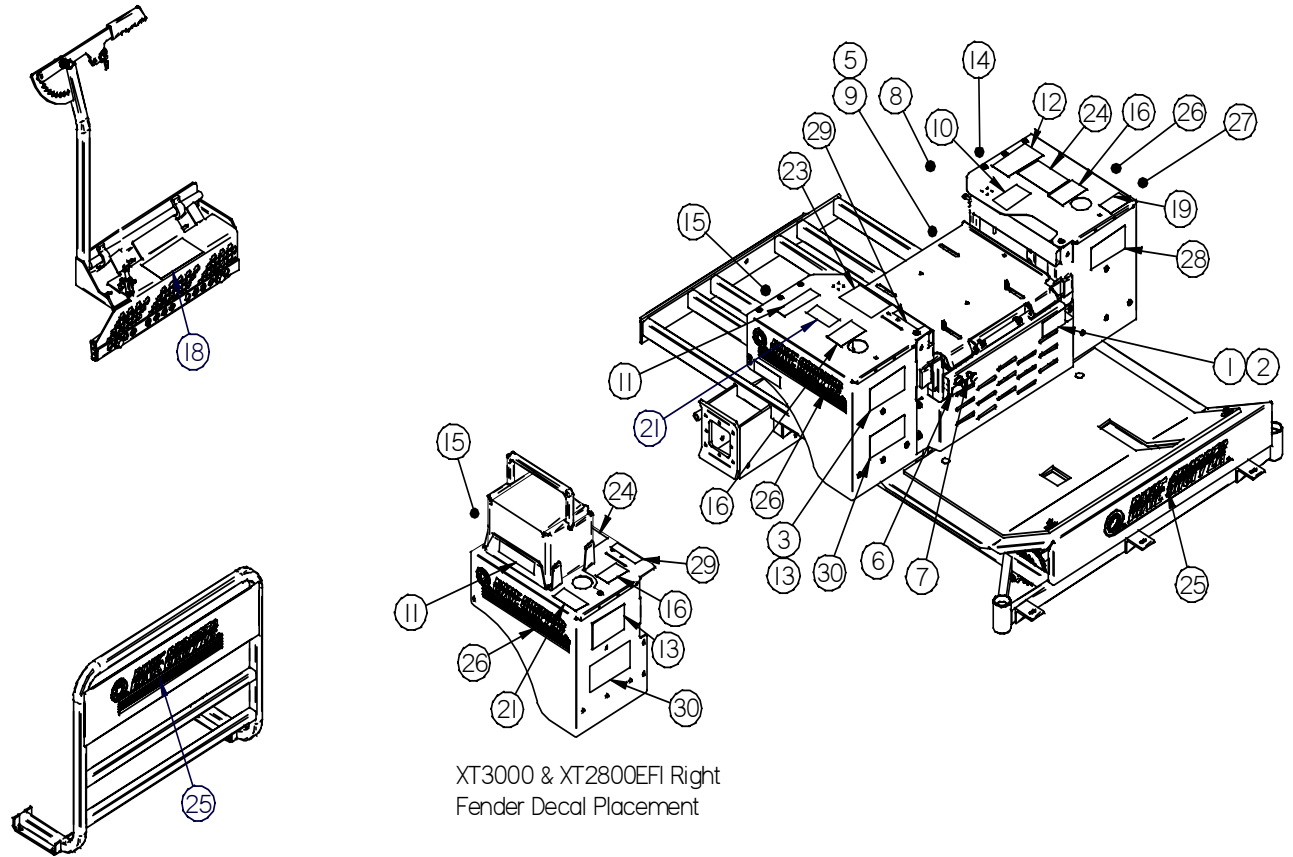

XT3000 & XT2800EFI Right
Fender Decal Placement

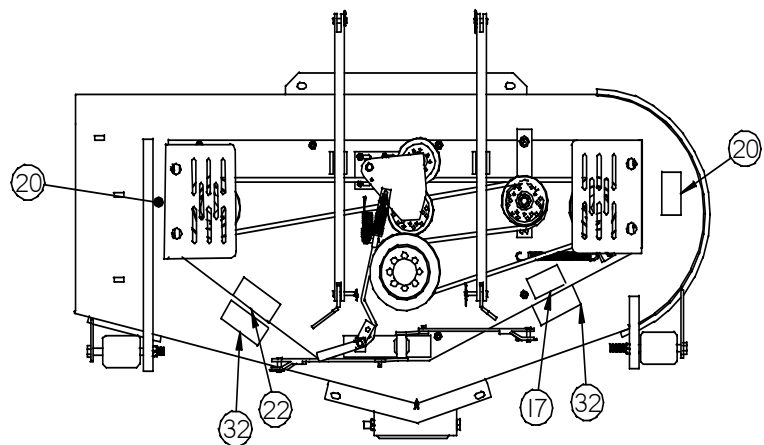

DIXIE CHOPPER

FRAME

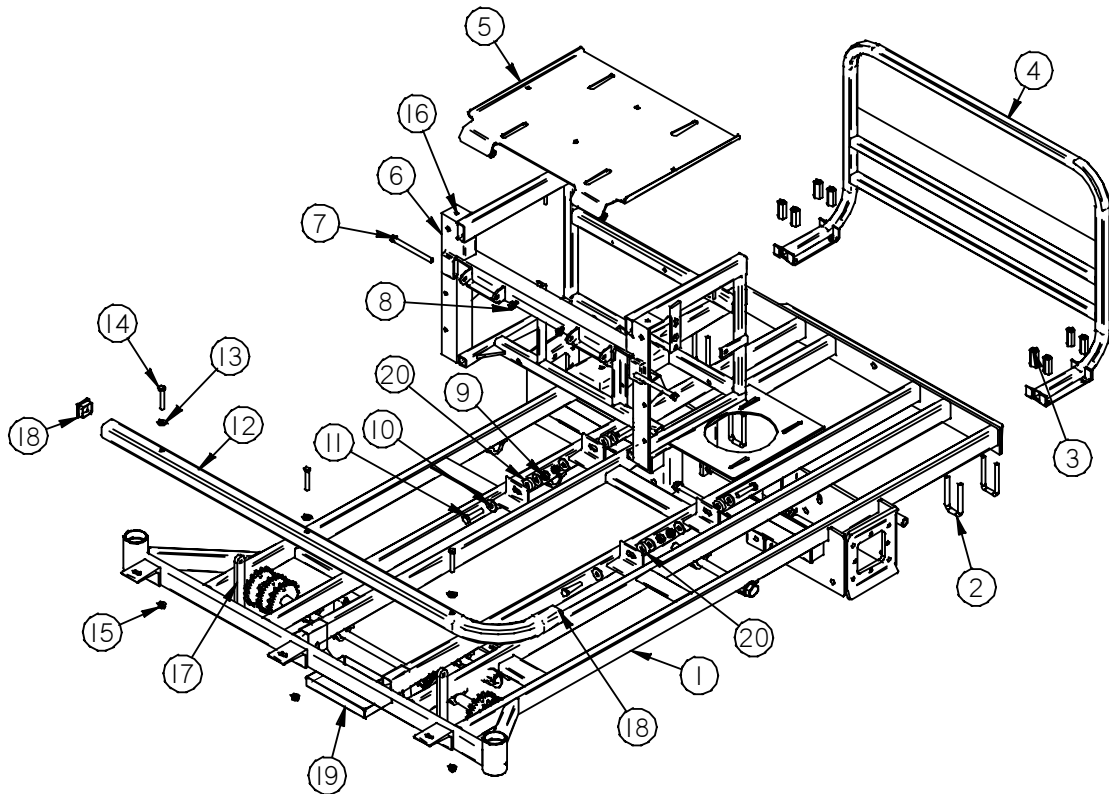

REF #	PART #	DESCRIPTION	QTY.
1	100017	XT - 72" Frame	1
	100031	XXW4600 Frame	
	100045	XT Generac 72" Frame	
2	B-200	3/8"-16 U-Bolt	4
3	N-160	3/8"-16 Coupling Nut	8
4	97096	Rear Guard	1
5	400026	Weldment - Low Ride Seat Pan w/ Hinge	1
6	100007	Weldment - Low Ride Transmission Frame	1
7	B-229	3/8"-16 x 5" Bolt	2
8	N-107	3/8"-16 Nylon Locknut	2
9	N-135	7/16"-20 Nyloc Nut	4
10	W-168	7/16" Standard Flat Washer	8
11	B-199	7/16"-20 x 2" Bolt (XXW4600)	4
	B-273	7/16"-20 x 2 1/2" (XT2800EFI & XT3000)	4

REF #	PART #	DESCRIPTION	QTY.
12	67045-72	Bumper - XXW	1
13	W-160	10mm Flat Washer	3
14	B-179	3/8-16x2 1/2" Bolt	3
15	N-108	3/8"-16 Whiz Flange Nut	3
16	N-152	1/4"-20 Insert Nut	6
17	400008	Mount - Floor Pan Hinge Frame	2
18	97169	Bumper Cap	2
19	400065	Standard Battery Box (XT2800 & XXW4600)	1
	B-190	3/8"-16x1 1/2" Carriage Bolt	2
	N-108	3/8"-16 Whiz Flange Nut	2
	97145	Diesel Battery Box (XT3000)	1
	B-190	3/8"-16x1 1/2" Carriage Bolt	2
	N-108	3/8"-16 Whiz Flange Nut	2
20	30242	Spacer (XT2800EFI, XT3000 Only)	4

DIXIE CHOPPER

XT3000 BATTERY BOX

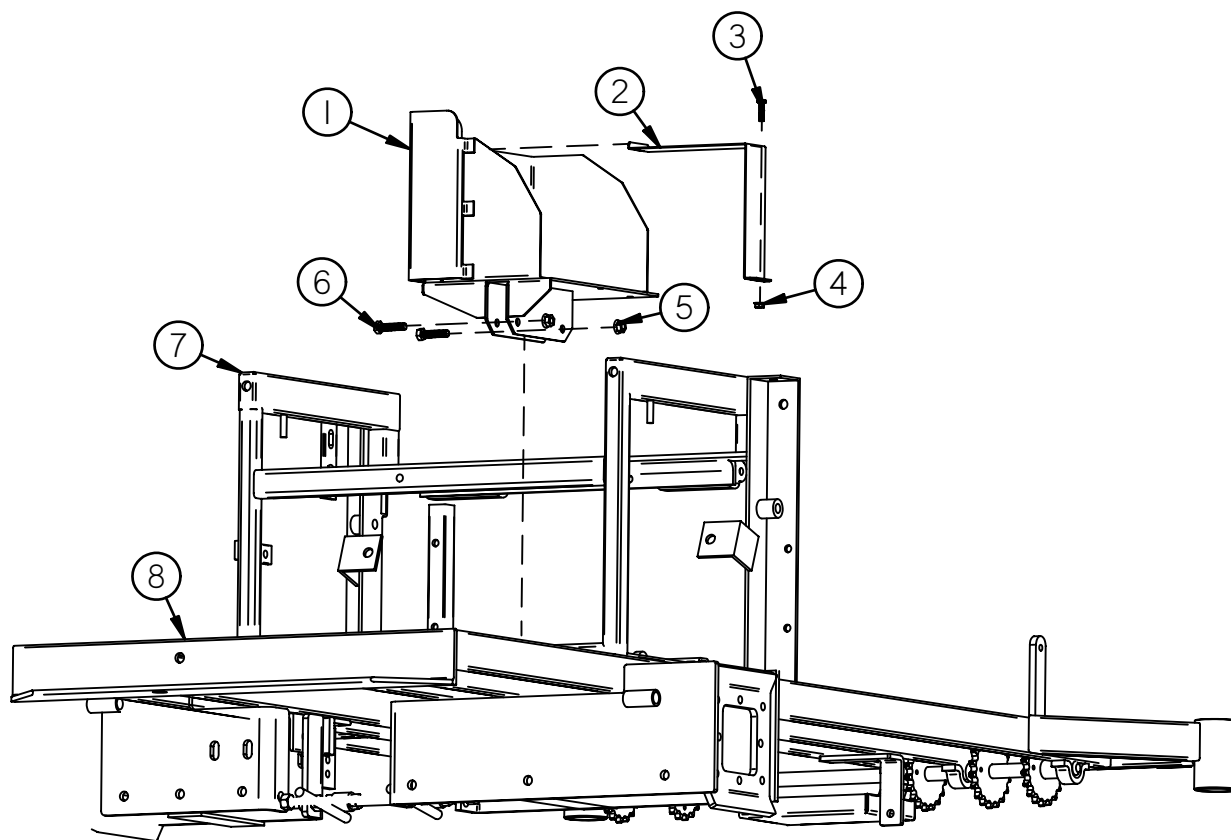

REF #	PART #	DESCRIPTION	QTY.
1	400072	Battery Box & Strap	1
2	400073	Strap	1
3	B-101	1/4"-20x1/2" Bolt	1
4	N-102	1/4"-20 Whiz Flange Nut	1
5	N-108	3/8"-16 Whiz Flange Nut	2
6	B-158	3/8"x1 1/2" Bolt	2
7	100007	Low Ride Transmission	1
8	100017	XT-72" Frame	1
	500008	Positive Battery Cable	1
	500009	Negative Battery Cable	1

DIXIE CHOPPER

XT3000 CROSSMEMBER

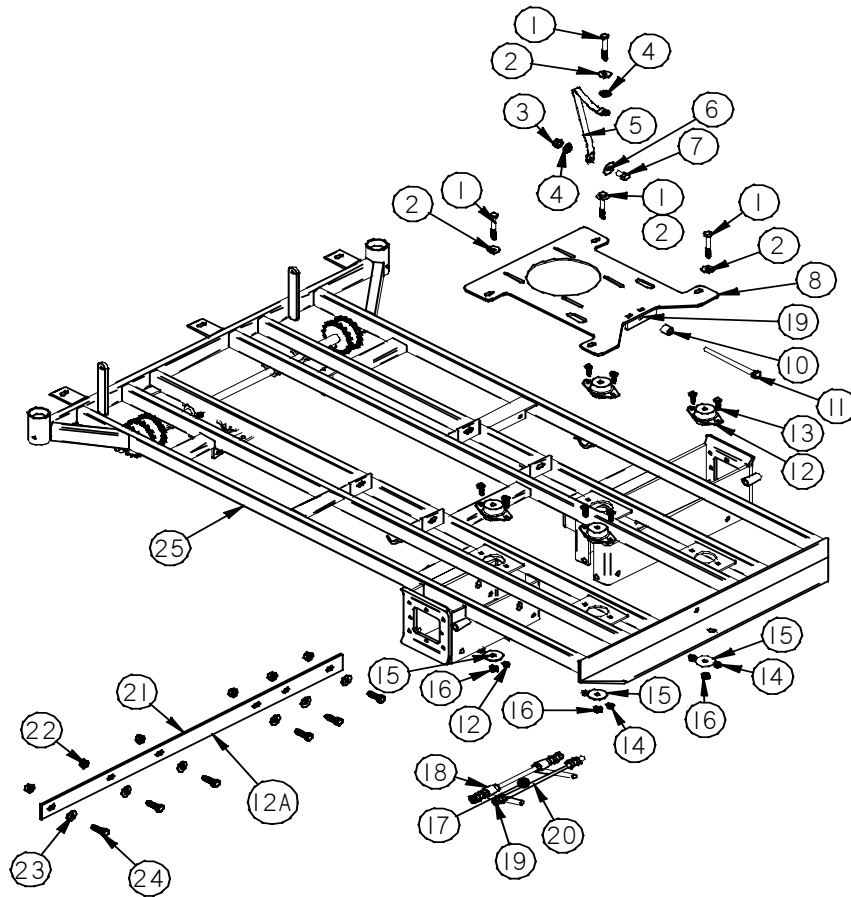

REF #	PART #	DESCRIPTION	QTY.	REF #	PART #	DESCRIPTION	QTY.
1	B-227	7/16"-14x3" Bolt	4	13	B-108	3/8"-16x1" Bolt	8
2	W-166	7/16" Flat Washer	4	14	N-108	3/8"-16 Whiz Flange Nut	8
3	N-157	1/2"-13 Whiz Flange Nut	1	15	W-159	7/16" ID x 2" OD Flat Washer	4
4	W-157	1/2" Star Tooth Washer	2	16	N-123	7/16"-14 Nyloc Nut	4
5	97382	Ground Strap	1	17	72220	Belt Guide Assembly (#18-#20)	1
6	W-128	1/2" Flat Washer	1	18	72217	Belt Guide Weldment	2
7	B-138	1/2"-13x1" Bolt	1	19	N-110	1/2"-13 Nut	13
8	100047	Weldment - Motor Mount Generac Plate w/Tensioning Tab	1	20	72222	All Thread 1/2"-13x12"	2
10	10203	Bushing	1	21	97024	Crossmember	1
11	B-202	1/2"-13x7" Tap Bolt	1	22	N-157	1/2"-13 Whiz Flange Nut	6
12	100048	Motor Mount	4	23	W-109	1/2" Flat Washer	6
12A	97008	Stop Void Warranty Decal	1	24	B-123	1/2"-13x1 1/2" Bolt	6
				25	100045	Frame - Generac XT 2003	1

DIXIE CHOPPER

XT2800EFI CROSSMEMBER & ENGINE ADJUSTMENT

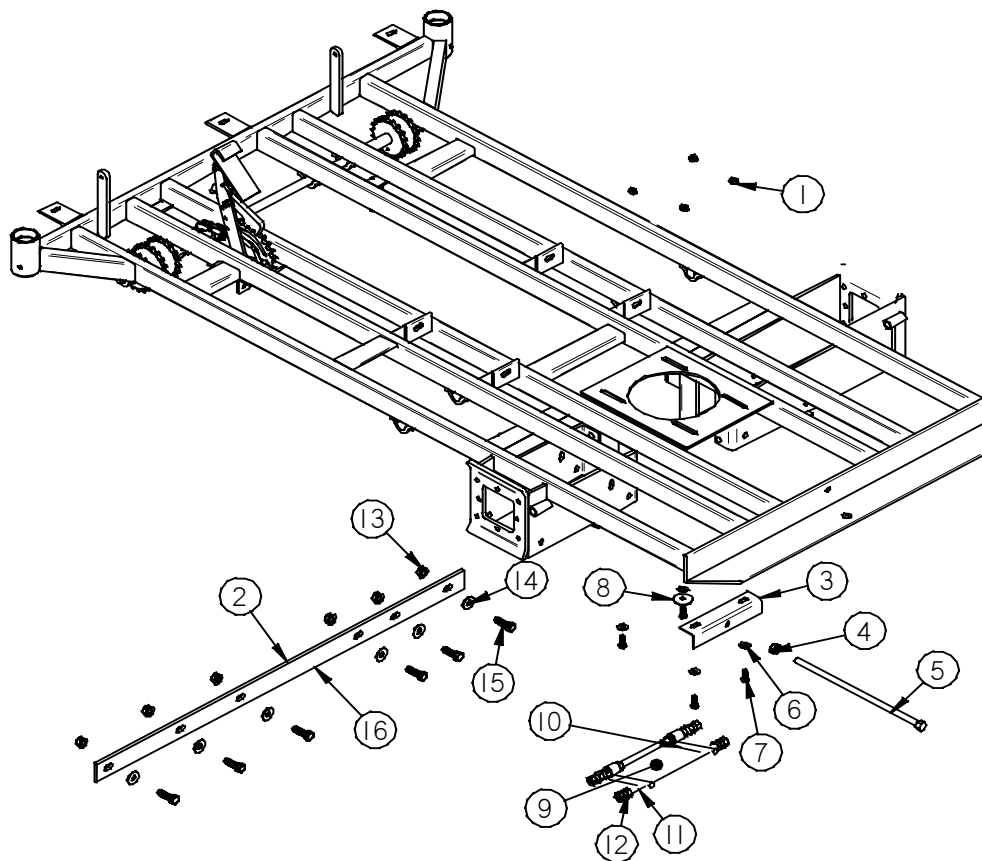

REF #	PART #	DESCRIPTION	QTY.
1	N-103-W	5/16"-18 Whiz Flange Nut	4
2	97024	Crossmember	1
3	72216	Pull Stop Weldment	1
4	N-110	1/2"-13 Nut	7
5	72221	16"x1/2" Bolt	1
6	W-113	5/16" Standard Flat Washer	4
7	B-156	5/16"-18x2" Gr.5 Bolt	4
8	W-107	3/8"x1 5/8" Beveled Washer	1

REF #	PART #	DESCRIPTION	QTY.
9	72220	Belt Guide Assembly (#10-#12)	1
10	72217	Belt Guide Weldment	2
11	72222	All Thread 1/2"-13x12"	1
12	N-110	1/2"-13 Nut	6
13	N-157	1/2"-13 Whiz Flange Nut	6
14	W-109	1/2" Flat Washer	6
15	B-123	1/2"-13x1 1/2" Bolt	6
16	97008	Stop Void Warranty Decal	1

DIXIE CHOPPER

XXW4600 CROSSMEMBER & CENTER HUB

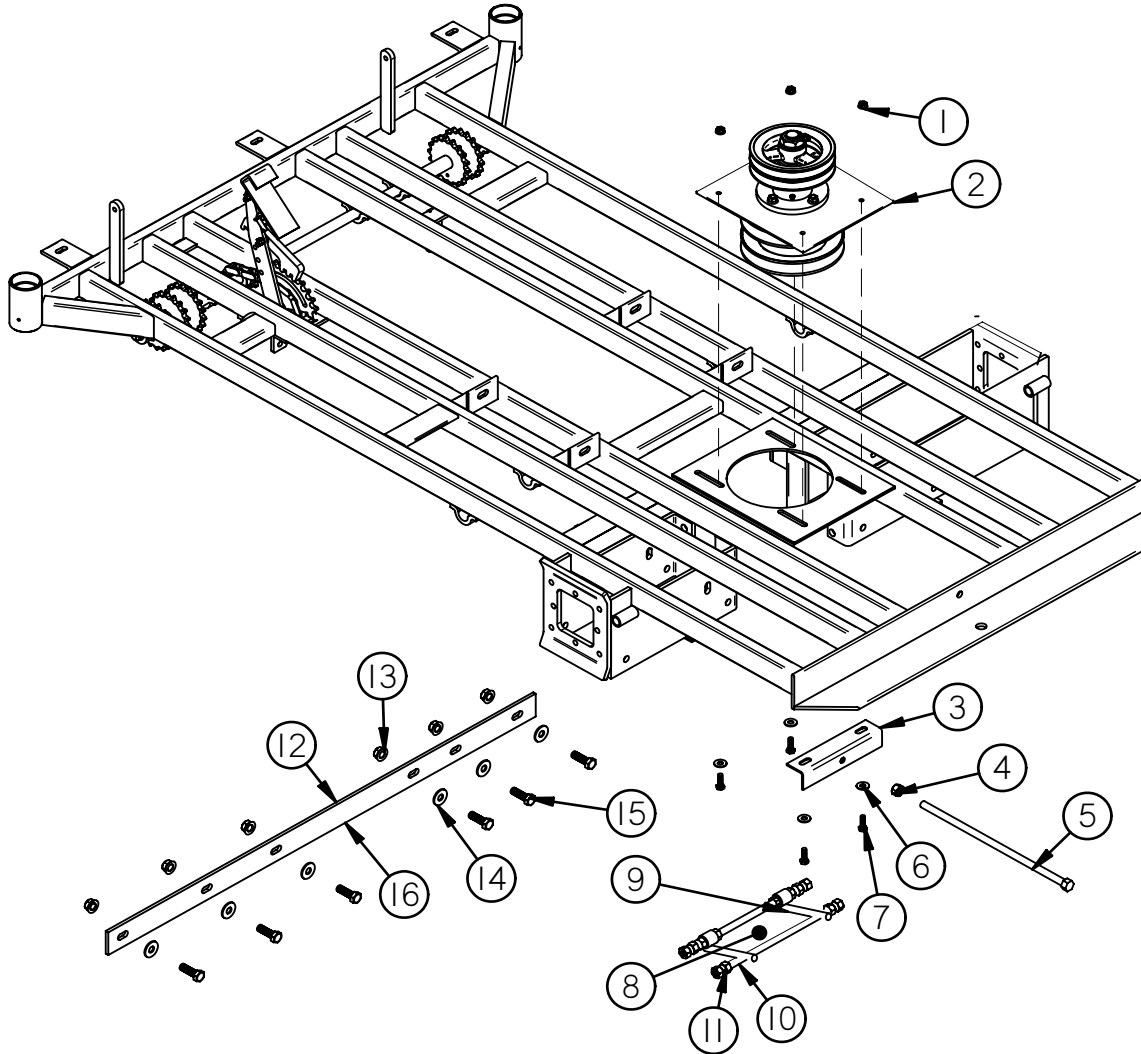

REF #	PART #	DESCRIPTION	QTY.
1	N-103-W	5/16"-18 Whiz Flange Nut	4
2	68242	Center Drive Hub Assembly (Narrow bolt pattern to rear of machine)	1
3	72216	Pull Stop Weldment	1
4	N-110	1/2"-13 Nut	7
5	72221	16"x1/2" Bolt	1
6	W-113	5/16" Standard Flat Washer	4
7	B-131	5/16"-18x1" Gr.5 Bolt	4
8	72220	Belt Guide Assembly (#9-#11)	1

REF #	PART #	DESCRIPTION	QTY.
9	72217	Belt Guide Weldment	2
10	72222	All Thread 1/2"-13x12"	1
11	N-110	1/2"-13 Nut	6
12	97024	Crossmember	1
13	N-157	1/2"-13 Whiz Flange Nut	6
14	W-109	1/2" Flat Washer	6
15	B-123	1/2"-13x1 1/2" Bolt	6
16	97008	Stop Void Warranty Decal	1

DIXIE CHOPPER

WHEELS & TIRES

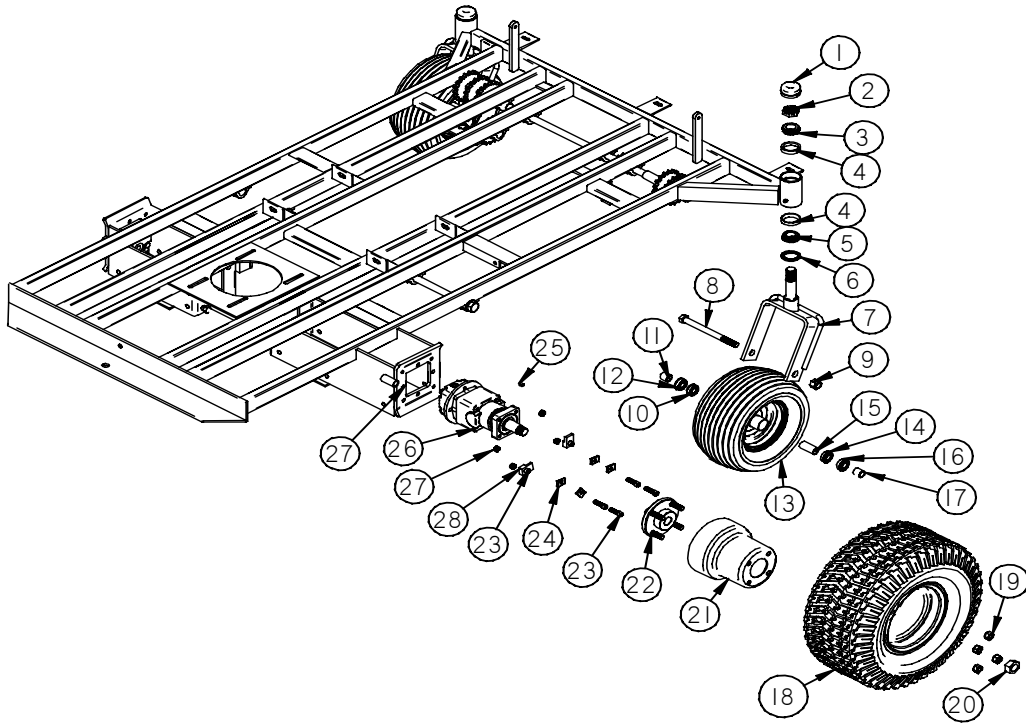

REF #	PART #	DESCRIPTION	QTY.
1	10220	Dust Cap	2
2	N-183	1"-14 Jam Nyloc Nut	2
3	10207	Top Bearing	2
4	10206	Outer Bearing Race	4
5	97171	Bottom Bearing	2
6	10208	Oil Seal	2
7	100019	Heavy Duty Fork	2
8	B-235	5/8"-11x9" Bolt	2
9	N-115	Nut - 5/8"-11 Nyloc	2
10	67205	Inner Front Wheel Bearing	2
11	400052	Outer Front Wheel Spacer	2
12	10205	Outer Front Wheel Bearing	2
13	400053	Front Tire Assembly	2
	400070	Front Tire	
	400071	Rim - 4.5"x6"x3.5" (only)	
	10127-S	Valve Stem	
14	67205	Inner Front Wheel Bearing	2
15	67204	Inner Front Wheel Spacer	2
16	10205	Outer Front Wheel Bearing	2
17	400052	Heavy Duty Fork Spacer	2

REF #	PART #	DESCRIPTION	QTY.
18	400042	Assembly - Turfpro Tire & Rim (26x12x12) (XT3000 & XXV4600)	2
	400055	Tire - 26x12x12 (Tire Only) (XT2800)	
	400054	Rim - 12x8.5 (Fit Tire 26x12x12)	
	10127-S	Valve Stem	
19	N-113	1/2"-20 Wheel Lug Nut	8
20	PB339303P	Wheel Motor Axle Nut	2
21	67266	Brake Drum (F/ XT2800 & XT3000)	2
22	67002	Wheel Flange w/studs (F/ XT2800 & XT3000)	2
23	B-183	1 1/4"x3/8" Allen Head Wheel Bolt (XT2800 & XT3000)	12
	B-123	1/2" -13x1 1/2" Bolt (XXV4600)	14
24	W-138	Wheel Motor Square Washer (XT2800 & XT3000)	8
25	PW72546	1/4" Key	2
26	67118-W	Wheel Motor 18Qu. In. (XT2800 & XT3000)	2
	200024	Wheel Motor 24Qu. In. (XXV4600)	2
27	N-127	3/8"-24 Locknut Wheel Motor Nut (XT2800 & XT3000)	12
	N-146	1/2" Stover Lock Nut (XXV4600)	14
28	990700138	Wheel Motor Block (XT2800 & XT3000)	4
	68211	Tire Sealant 1 Liter Bottle (Optional)	
		Front Tire @ 1 Liter	
		Rear Tire @ 2 Liter	

DIXIE CHOPPER

FOOT PEDAL ASSEMBLY

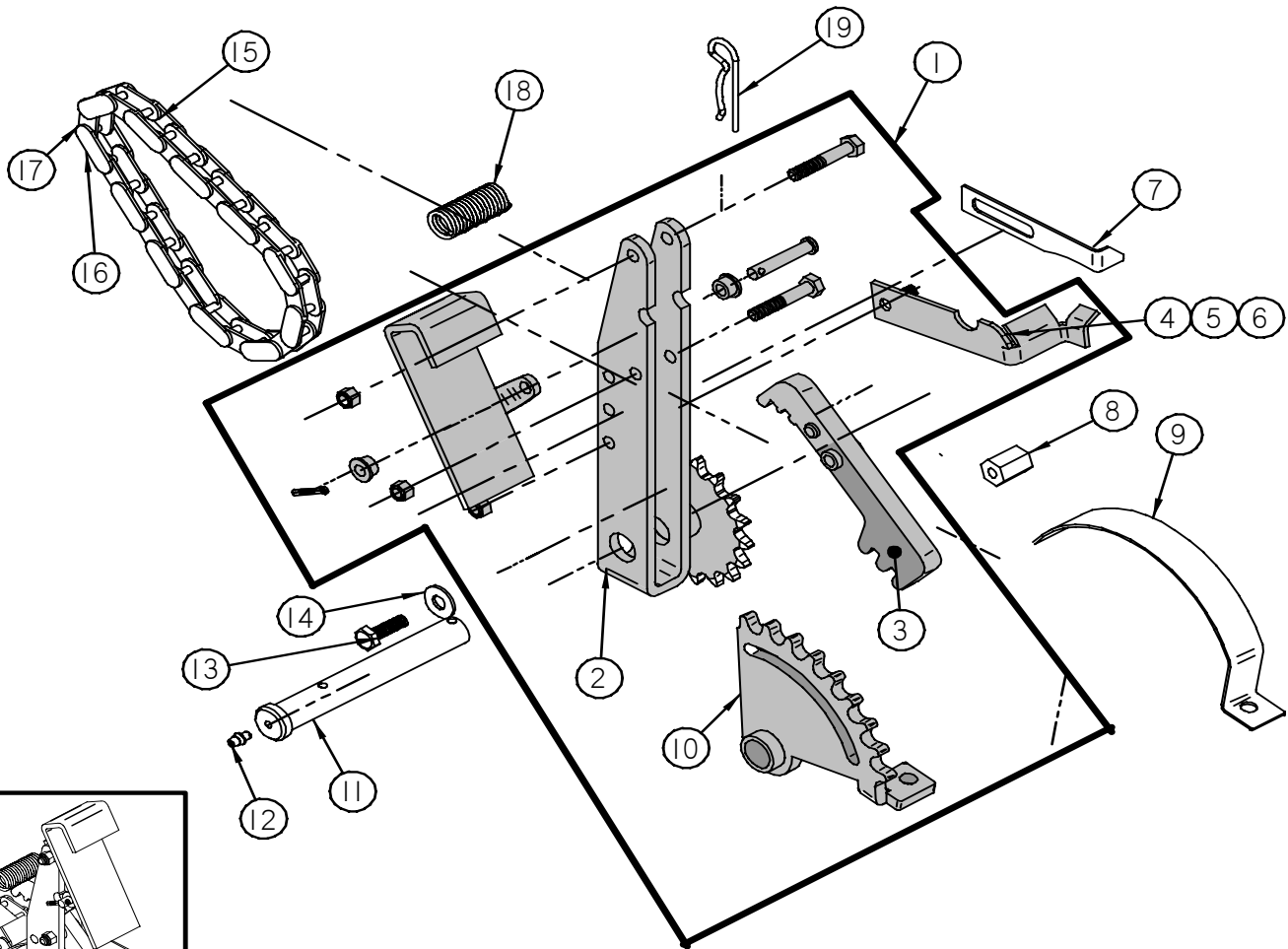

REF #	PART #	DESCRIPTION	QTY.
1	10107-1/2	Kit - Foot Pedal	1
2	10225-2	Weldment - #50 Foot Lift Arm	1
3	10224-1	Pawl	1
4	990735020	Foot Pedal Lock (Incl. #5 - #6)	1
5	W-164	5/16" Wafer Spring Washer	1
6	N-144	5/16"-18 Nylon Jam Nut	1
7	300008	Deck Height Pointer	1
8	N-130	5/16"-18x1 3/4" Coupling Nut	1
9	300007	Deck Height Indicator	1
10	10226-1	Lift Sprocket	1

REF #	PART #	DESCRIPTION	QTY.
11	10228-1	Pin	1
12	F-100	3/16" Drive-In Grease Fitting	1
13	B-131	5/16"-18x1" Bolt	1
14	W-113	5/16" Standard Flat Washer	1
15	68219	#50 Chain (include ref.#16)	1
16	10233	#50 Half Link	1
17	10232	#50 Master Link	1
18	20217-25	Spring	1
19	30213	Hair Pin Clip	1

DIXIE CHOPPER

DECK LIFT SYSTEM

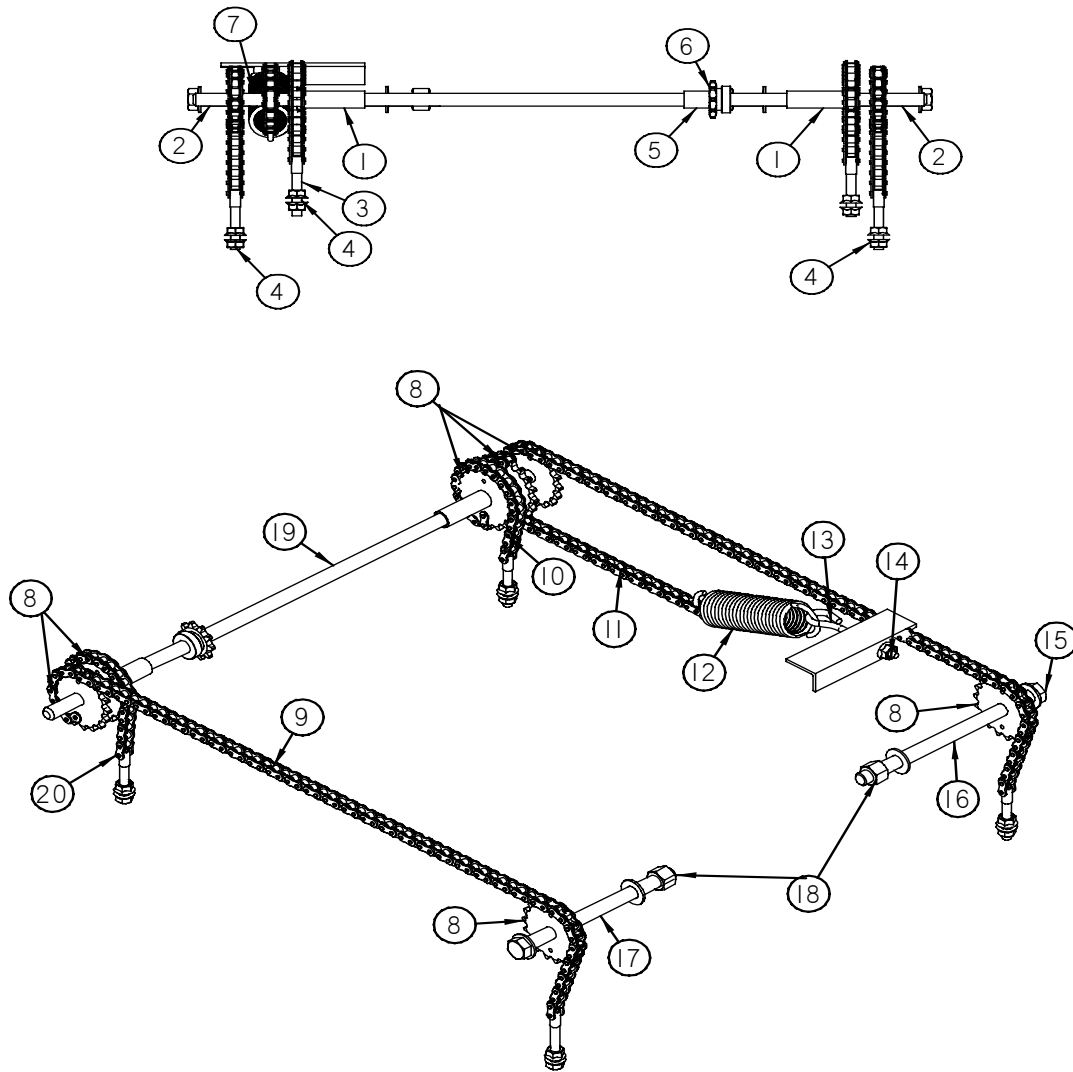

REF #	PART #	DESCRIPTION	QTY.
1	68108	2 7/8" Long Bushing	2
2	65047	3/4" Long Bushing	2
3	S-114	1/2"-13 Stud	4
4	N-157	1/2"-13 Whiz Flange Nut	8
5	68105	3/8" Long Bushing	1
6	68104	#50 Small Sprocket	1
7	68106	1 3/16" Bushing	1
8	68103	Deck Lift Sprocket #50	7
9	990710005	#50 Rear Deck Lift Chain	2
10	68217	#50 Front Deck Lift Chain	2
11	990710002	#50 Return Spring Chain	1
12	97456	225 lb. Return Spring	1

REF #	PART #	DESCRIPTION	QTY.
13	B-241	3/8"-16 Eye Bolt	1
14	N-108	3/8"-16 Whiz Flange Nut	1
15	W-154	3/4" Flat Washer	4
16	B-240	3/4"-10x11" Bolt	1
17	B-239	3/4"-10x10" Bolt	1
18	N-158	3/4"-10 Nyloc Nut	2
19	68110	3/4" x 34 3/4" Rod	1
20	10232	#50 Master Link	10

DIXIE CHOPPER

72" OCDC

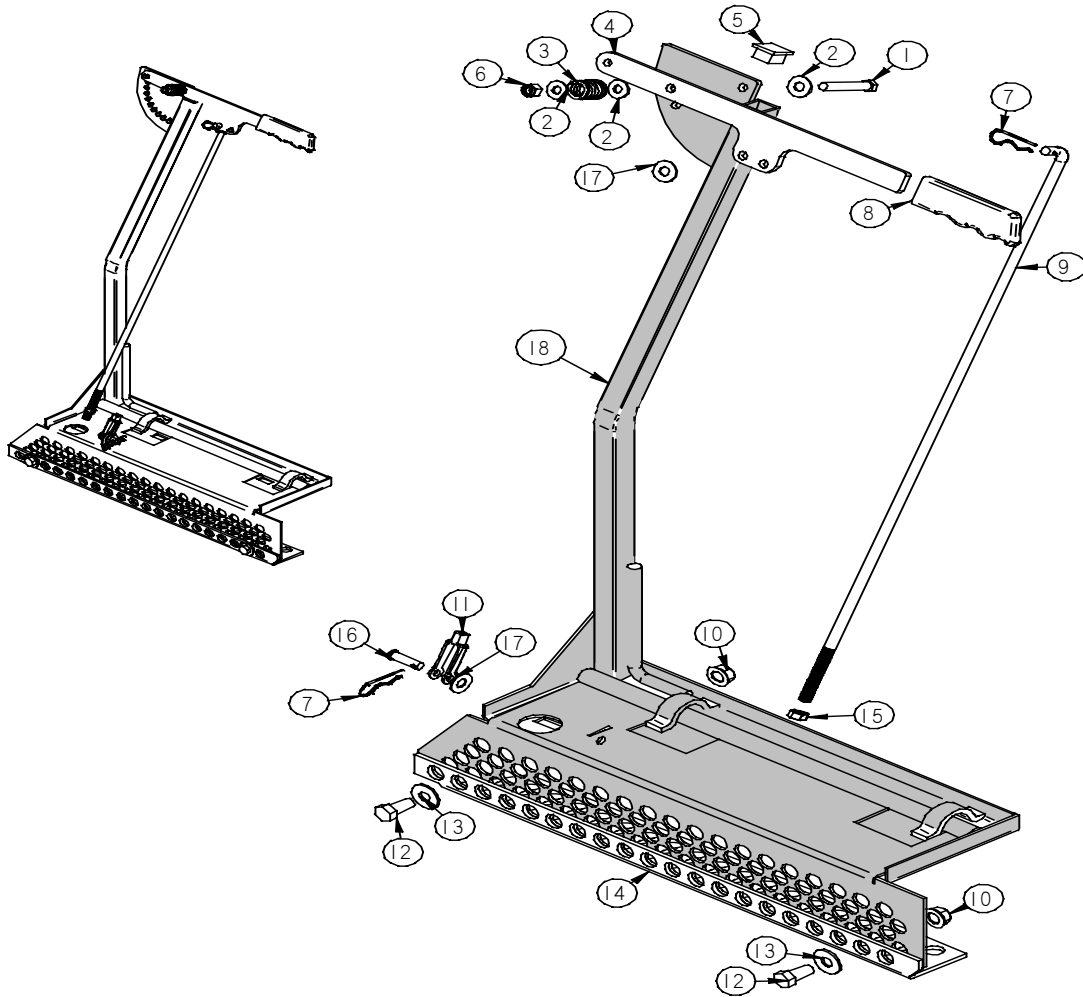

REF #	PART #	DESCRIPTION	QTY.
	72122	Assembly - 72" OCDC	
1	B-179	3/8"-16 x2.5" Bolt	1
2	W-104	3/8" Standard Flat Washer	3
3	20252	Spring	1
4	900014	Handle	1
5	68142	1"x1" Plastic Plug	1
6	N-107	3/8"-16 Nylon Locknut	1
7	20224	Hair Pin Clip	2
8	67258	Handle Grip	1

REF #	PART #	DESCRIPTION	QTY.
9	68130	Control Rod (Inc. #9,11,15)	1
10	N-157	1/2"-13 Whiz Flange Nut	2
11	68121	3/8"-24 Yoke	1
12	B-138	1/2"-13x1" Bolt	2
13	W-109	1/2" Standard Flat Washer	2
14	72123	Lower Screen	1
15	N-150	3/8"-24 Nut	1
16	P-102	3/8"x1.25" Clevis Pin	1
17	W-104	3/8" Standard Flat Washer	2
18	68122-72W	Weldment - 72" OCDC	1

DIXIE CHOPPER

72" Deck

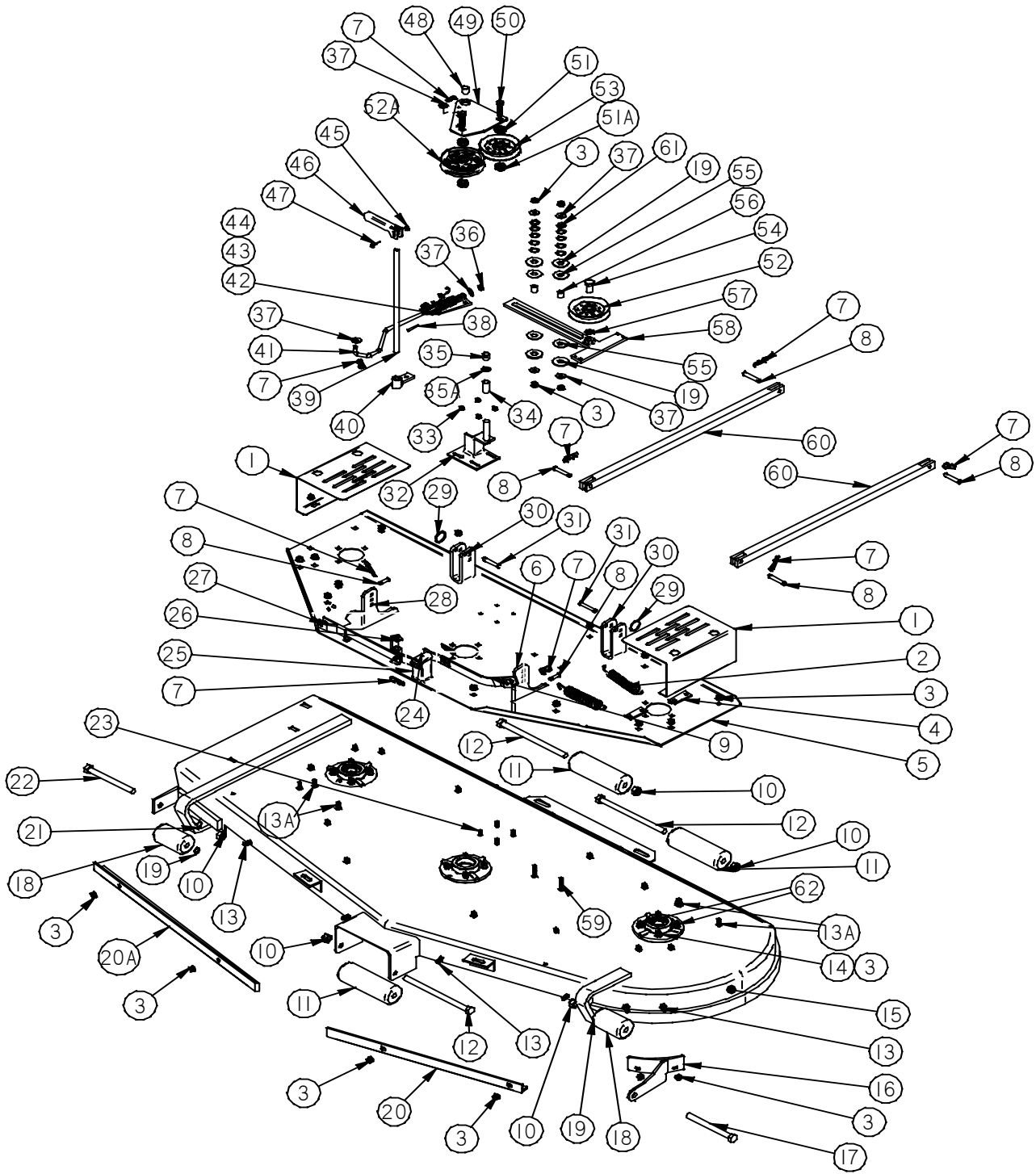

DIXIE CHOPPER

72" DECK (CONT'D)

REF #	PART #	DESCRIPTION	QTY.	REF #	PART #	DESCRIPTION	QTY.
	300025	XT - 72" Complete Deck		33	N-102	1/4" - 20 Whiz Flange Nut	4
	72300-72T	Twin Complete Deck 72"		34	10203	1" Shim (if needed)	*
	300020	Deck - Standard 72"		35	65278	1/2" Shim (if needed)	*
1	300047	Pulley Guard	2	35A	30112	1/8" Shim (if needed)	*
2	10222	Spring	2	36	N-107	3/8 -16 Nylon Lock Nut	1
3	N-108	3/8" Whiz Flange Nut	51	37	W-104	3/8" Flat Washer	6
4	65308	Idler Spring Tab	2	38	P-113	3/16"x1" Roll Pin	1
5	300016	72" Top Plate Weldment	1	39	30211	Enguaging Shaft	1
6	334000130111	Left 3-Hole Tab	1	40	30210	Cam Weldment	1
7	20224	Hairpin Clip	10		30209-1	Enguaging Rod Assembly (Inc. #36,37,41,42,43)	
8	P-102	3/8"x1.25" Clevis Pin	6	41	97343	Enguaging Rod	1
9	30232	Left Scissor Arm	1	42	30209-B	Connecting Arm Bracket	1
10	N-156	5/8"-11 Nyloc Jam Nut	5	43	30207-S	Enguaging Spring	1
11	30240-0	Long Roller	3	44	20217-25	Return Spring	1
12	B-255	5/8"-11x9" Carriage Bolt	3	45	N-173	#10 Nyloc Nut	1
13	B-110	3/8"-16x3/4" Carriage Bolt	29	46	30212	Enguaging Handle	1
13A	B-135	3/8"-16x1" Carriage Bolt	4	47	B-245	#10-24x1 1/4" Carriage Bolt	1
14	B-136	3/8"-16x1.25" Carriage Bolt	10	48	30206	5/8"x1/2" Bushing (Brass)	1
15	300014	72" Deck Weldment (Includes 15,16,20,20A)	1		300012	Triangle Plate Assembly Inc. #48,49,50,51,51A,F-102	1
16	300017	Weldment - Roller Bracket	1	49	300011	Weldment- Triangle Plate	1
17	B-253	5/8"-11x6" Carriage Bolt	1	50	B-185	5/8"-11 x 2" Bolt	2
18	67240	Short Roller	2	51	N-180	5/8"-11 Jam Lock Nut	2
19	W-135	5/8" Flat Washer	6	51A	N-181	5/8"-11 Center Lock Nut	2
20	300019	Left Blowout Baffle	1	52	68224	Flat Idler Pulley	1
20A	300018	Right Blowout Baffle	1	52A	30224	Flat Idler Pulley	1
21	10203	Spacer	1	53	30234	V Idler Pulley	1
22	B-254	5/8"-11x7" Carriage Bolt	1	54	B-117	1/2"-13x1.25" Bolt	1
23	B-172	1/4"-20x1" Bolt	4	55	W-140	5/8" ID. Nylon Washer	4
24	F-100	3/16" Drive in Grease Fitting	2	56	61250	T-Idler Slide Bushing	2
25	67131	Scissor Link Tower Weldment	1	57	W-112	1/2" Lock Washer	1
26		Enguaging Tower Weldment	1	58	68225	T-Idler Slide	1
27	30231	Right Scissor Arm	1	59	B-223	3/8"-16x2 1/4" Carriage Bolt	2
28	334000130110	Right 3-Hole Tab	1	60	30214-72	Stabilizer Bar	2
29	C-104	Ring Clip	2	61	W-149	Waffer Washer	10
30	100030	3 Hole Tab	2	62	B-190	3/8"-16x1 1/2"	2
31	P-103	3/8" x 2" Clevis Pin	2				
32	97006	Pivot Stand	1				
	300024	Pivot Stand F/ Generac 72"					

* Use individually or a combination of 10203, 65278 and 30112 to achieve proper belt alignment between the triangle plate and the top center deck spindle pulley.

DIXIE CHOPPER

XT2800EFI & XT3000 HUBS AND BELTS

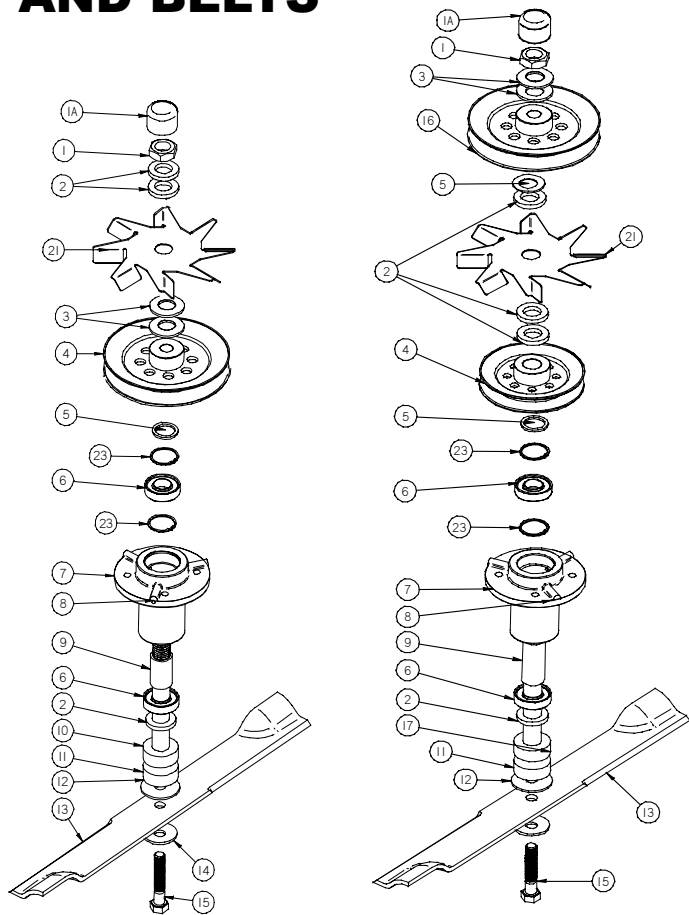
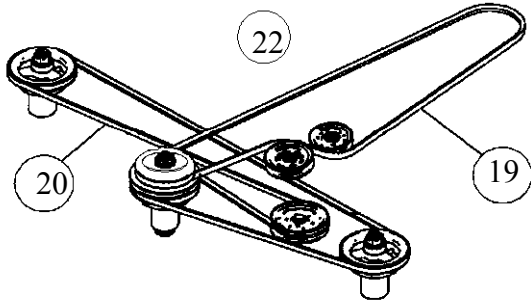

REF #	PART #	DESCRIPTION	QTY.
	10161	Outside Complete Spindle Assembly	2
	10161-L	Center Complete Spindle Assembly	1
1	N-167	1"-14 Jam Nut	3
1A	67255	Spindle Cap	3
2	W-146	1/4" Washer	10
3	W-137	1" Belleville Washer	6
4	9907675X100S	6.75" Split Pulley	3
5	W-131	1/8" Washer	4
6	30218	Sealed Bearing	6
7	30241	Deck Hub	3
8	F-102	Grease Fitting	3
9	30219	Inner Deck Hub Spacer	3
10	30217	Short Blade Shaft	2
11	30242	1/2" Blade Spacer	3
12	W-101	2 1/4" OD. Fiber Washer	3

REF #	PART #	DESCRIPTION	QTY.
13	30227-72H	72" Standard High Lift Blades	3
	30227-72N	72" Heavy Duty Lift Blade (Optional)	3
	98125	Hard-Faced 72" Blades (Optional)	3
	98007	Offset 72" Blades (Optional)	3
14	W-100	5/8" Belleville Washer	3
15	B-121	2.5" Blade Bolt (use w/o blade spacer)	3
	B-121-L	3" Blade Bolt (use with blade spacer)	3
	B-121-LL	3.25" Blade Bolt (use with Whiz-Mow)	3
16	9907750X100S	PULLEY - 7 1/2" F/ all XT 72" DECK	1
17	30217-L	Long Blade Shaft	1
18	30302	Whiz-Mow (Optional)	3
19	9907B85	BELT - Engine to Deck (B-85)	1
20	68162	Deck Belt (B-162)	1
21	300026	Fan - 8 1/4"	3
22	9907B41	Engine - Trans. Belt (not shown) (B-41)	1
23	788080	Snap Ring	6

DIXIE CHOPPER

XXW4600 TWIN HUBS AND BELTS

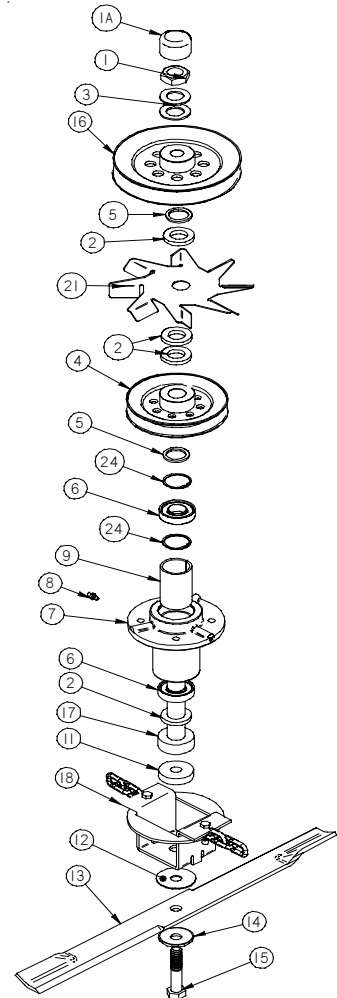
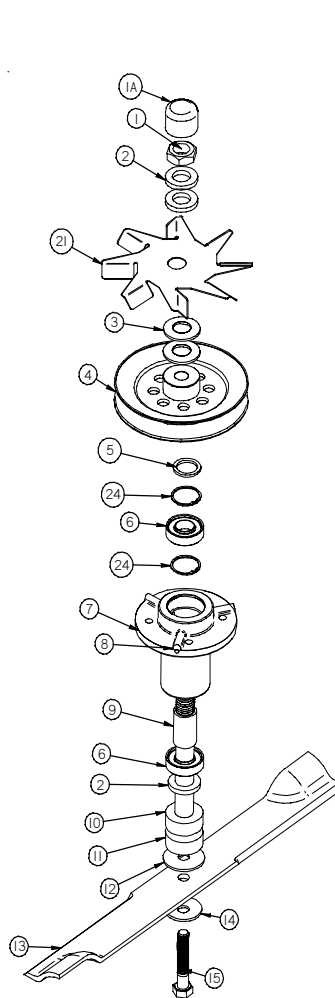
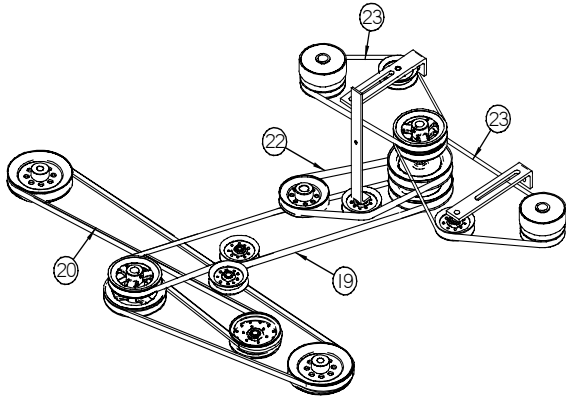

REF #	PART #	DESCRIPTION	QTY.
	10161	Outside Complete Spindle Assembly	2
	10161-L	Center Complete Spindle Assembly	1
1	N-167	1"-14 Jam Nut	3
2	W-146	1/4" Washer	10
3	W-137	1" Belleville Washer	6
4	9907675X100S	6.75" Split Pulley	3
5	W-131	1/8" Washer	4
6	30218	Sealed Bearing	6
7	30241	Deck Hub	3
8	F-102	Grease Fitting	3
9	30219	Inner Deck Hub Spacer	3
10	30217	Short Blade Shaft	2
11	30242	1/2" Blade Spacer	3
12	W-101	2 1/4" OD. Fiber Washer	3
13	30227-72H	72" Standard High Lift Blades	3
	30227-72N	72" Heavy Duty Lift Blade (Optional)	3
	98125	Hard-Faced 72" Blades (Optional)	3
	98007	Offset 72" Blade (Optional)	3

REF #	PART #	DESCRIPTION	QTY.
14	W-100	5/8" Belleville Washer	3
15	B-121	2.5" Blade Bolt (use w/o blade spacer)	3
	B-121-L	3" Blade Bolt (use with blade spacer)	3
	B-121-LL	3.25" Blade Bolt (use with Whiz-Mow)	3
16	9907600X100S	6.00" Pulley	1
17	30217-L	Long Blade Shaft	1
18	30302	Whiz-Mow (On all Spindle Hubs)	3
19	68082	Engine - Deck Belt (B-82)	1
20	68162	Deck Belt (B-162)	1
21	300026	Fan - 8 1/4"	3
22	97345	Engine - Trans. (B-40)	1
23	20256	Clutch - Center Drive Belt (B-38)	2
24	788080	Snap Ring	6

DIXIE CHOPPER

XT2800,XT3000,XXW4600

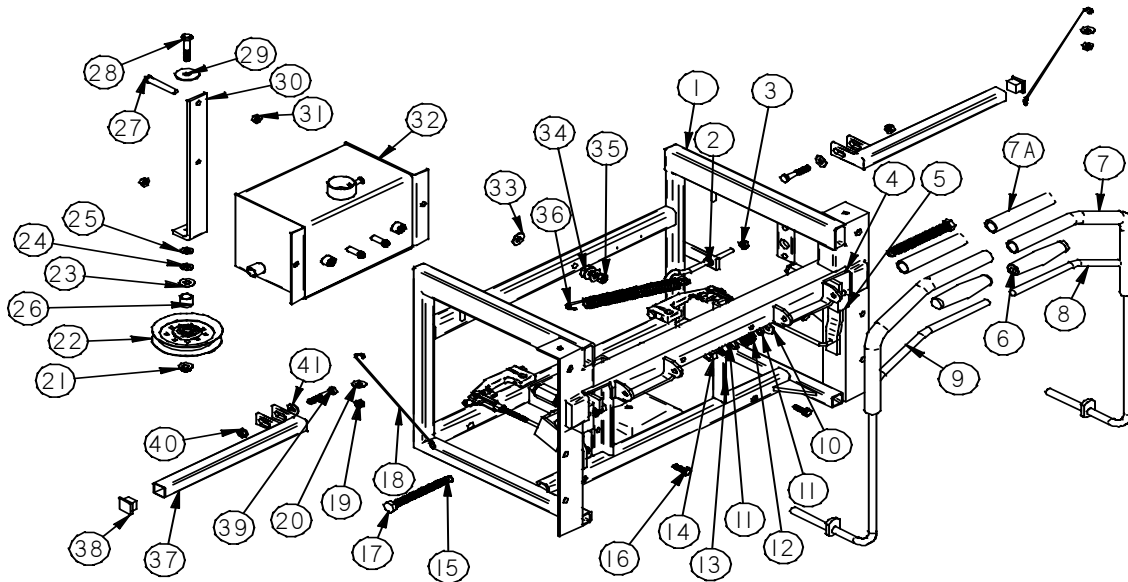

REF #	PART #	DESCRIPTION	QTY.
1	100007	Low Ride Transmission Frame	1
2	B-150	5/16"x 2 1/2" Eye Bolt	1
3	N-103W	5/16"-18 Whiz Flange Nut	2
4	W-171	1/2" IDx1 1/4" OD Teflon Washer	2
5	65205	Steering Block Weldment	2
6	20257	Rubber Handle	2
7	400037	Foam Lever Sleeve	2
7A	67259	Foam Grip	2
8	20231-L 20231	Left Steering Lever XT,30, Left Steering Lever XXW4600 / XT28	1 1
9	20232-L 20232	Right Steering Lever XT,30, Right Steering Lever XXW4600 / XT28	1 1
10	W-170	1/2" IDx7/8" OD Teflon Washer	2
11	W-110	1/2" Machine Washer	4
12	20252	Spring	2
13	N-110	1/2"-13 Nut	2
14	N-111	1/2"-13 Hex Nut	2
15	F-101	Grease Fitting 90 degree	2
16	B-131	5/16-18x1" Bolt	2
17	B-143G	1/2"x4 1/2" Bolt	2
18	40218	Seat Strap	2

REF #	PART #	DESCRIPTION	QTY.
20	W-113	5/16" Standard Washer	2
21	N-117	3/8"-16 Large Flange Lock Nut	1
22	30234	Pulley	1
23	W-124	3/8" Machine Washer .120"	
24	W-123	3/8" Machine Washer .060"	
25	W-176	3/8" Machine Washer .031"	
26	97415	Spacer - Inside Pulley	1
27	B-165	3/8"-16x2 Bolt	1
28	B-124	3/8"x16x1 3/4"	1
29	W-104	3/8 Standard Flat Washer	1
30	100011	Idler Arm	1
31	N-103W	5/16"-18 Whiz Flange Nut	2
32	200008	Hydraulic Tank	1
33	W-125	3/8"x7/8" Washer Plastic	1
34	W-126	3/8" Washer	3
35	N-107	3/8"-16 Nylon Locknut	1
36	10222	Spring	1
37	97021	Fender Bracket	2
38	68142	Plug	2
39	B-165	3/8"-16x2" Bolt	2
40	N-108	3/8"-16 Whiz Flange Nut	2

DIXIE CHOPPER

XT2800EFI,XT3000 TRANSMISSION FRAME ASSEMBLY (CONT'D)

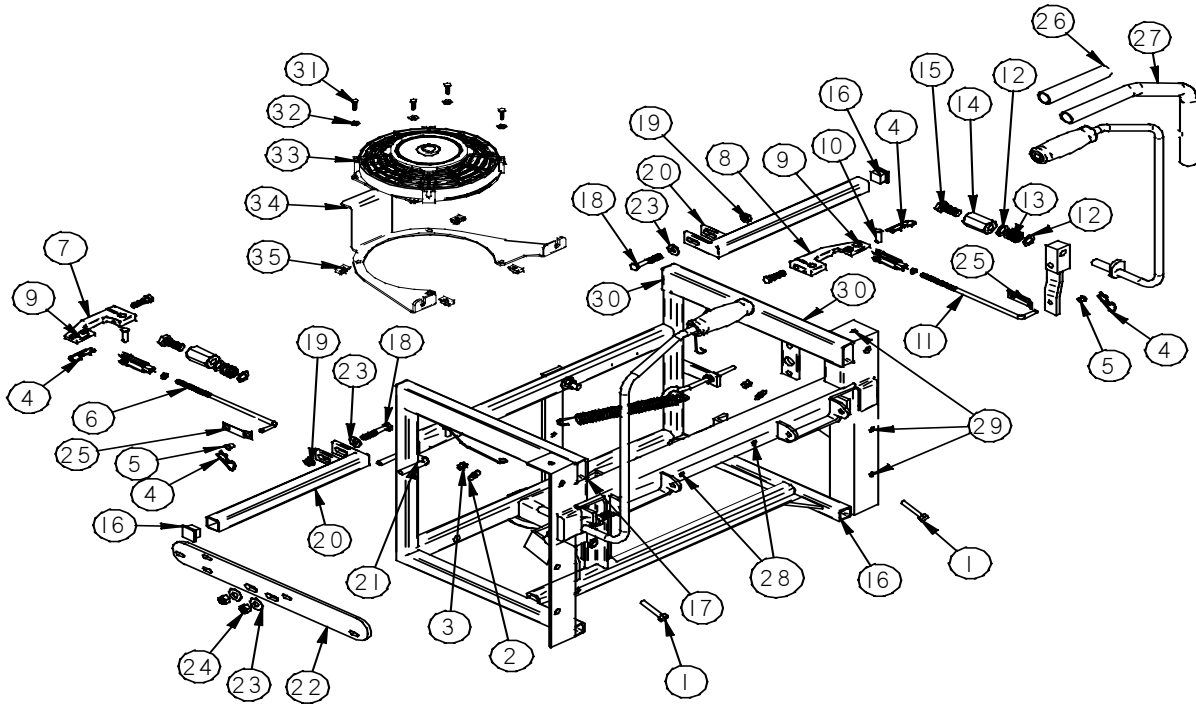

REF #	PART #	DESCRIPTION	QTY.
1	B-129	5/16"-18 x 2 1/4" Bolt	2
2	W-113	5/16" Standard Washer	2
3	N-103	5/16"-18 Hex Nut	2
4	20224	Hairpin Clip	2
5	20222	Plastic Bushing	2
6	200020	Right Pump Control Rod	1
	20214	Yoke	1
	N-105	5/16"-24 Hex Nut	1
7	200004	Right Pump Control Arm	1
	P-118	Roll Pin	1
	B-131	5/16"-18x1 Bolt	1
8	200005	Left Pump Control Arm	1
	P-118	Roll Pin	1
	B-131	5/16"-18x1 Bolt	1
9	20221	Plastic Bushing	2
10	P-101	Pin	2
11	200019	Left Pump Control Rod	1
	20214	Yoke	1
	N-105	5/16"-24 Hex Nut	1
12	W-110	1/2" Machined Bushing	4
13	20252	Spring	2

REF #	PART #	DESCRIPTION	QTY.
14	N-175	1/2"-13 Coupling Nut	2
15	B-138	1/2"-13x1" Bolt	2
16	68142	Plastic Plug 1"x1"	4
17	67256	Plastic Plug 1"x2"	2
18	B-165	3/8"-16x2" Bolt	2
19	N-108	3/8"-16 whiz Flange Nut	2
20	97021	Wide Fender Brace	2
21	B-206	3/8"-16x1 3/8wx2"L U-Bolt (EFI ONLY)	1
22	600031	EFI Module Mount (EFI ONLY)	1
23	W-104	3/8" Flat Washer (EFI ONLY)	4
24	N-107	3/8"-16 Nylon Locknut (EFI ONLY)	2
25	20223	Spring Backing Clip	2
26	67259	Foam Grip	2
27	400037	Foam Lever Sleeve	2
28	N-188	Insert Nut	2
29	N-152	1/4 Insert Nut	6
30	N-153	5/16 Insert Nut	4
31	B-203	10-24x3/4" Bolt	4
32	W-152	#10 Washer	4
33	200043	Electric Fan	1
34	200042	Electric Fan Mount	1
35	C-105	U-Clips	4

DIXIE CHOPPER

XXW4600 TRANSMISSION FRAME ASSEMBLY

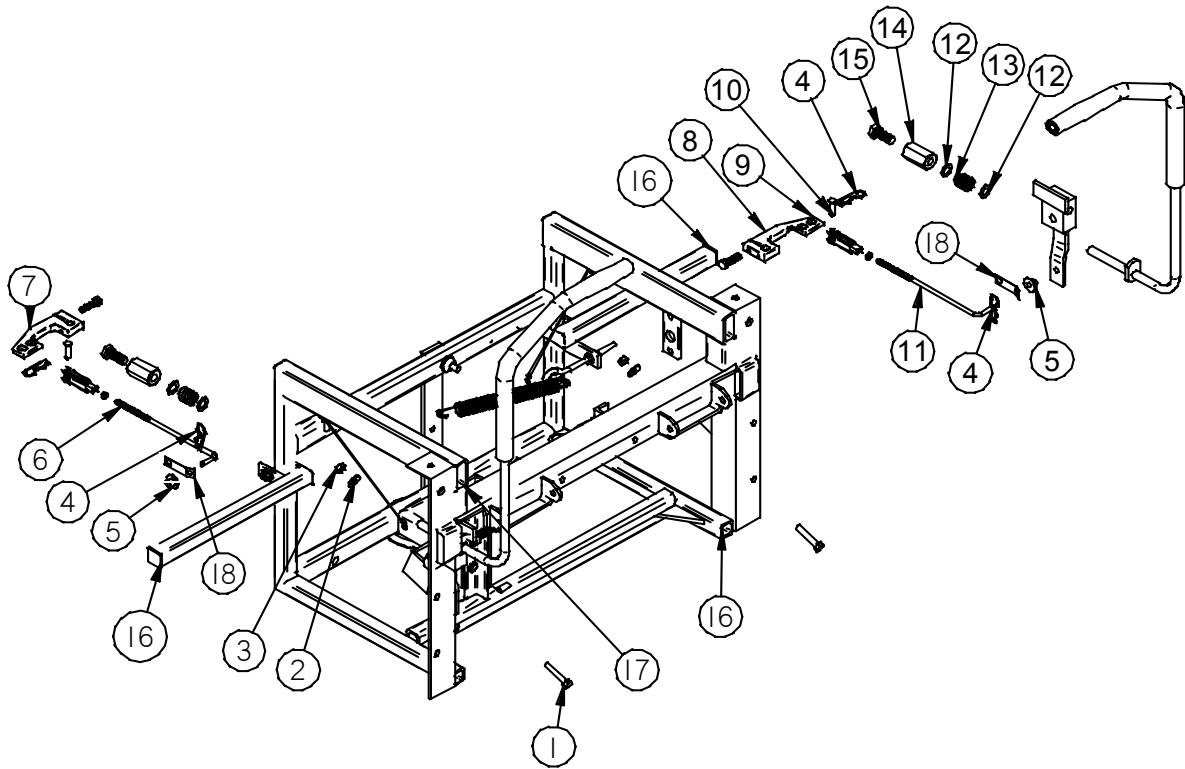

REF #	PART #	DESCRIPTION	QTY.
1	B-105	5/16"-16x1 3/4" Bolt	2
2	W-113	5/16" Standard Washer	2
3	N-103	5/16"-18 Hex Nut	2
4	20224	Hairpin Clip	2
5	20222	Plastic Bushing	2
6	200001	Right Pump Control Rod	1
	20214	Yoke	1
	N-105	5/16"-24 Hex Nut	1
7	72207	Right Pump Control Arm	1
	P-118	Roll Pin	1
	B-131	5/16"-18x1" Bolt	1
8	72207	Left Pump Control Arm	1
	P-118	3/16"x1 1/2" Roll Pin	1
	B-131	5/16"-18x1" Bolt	1

REF #	PART #	DESCRIPTION	QTY.
9	20221	Plastic Bushing	2
10	P-101	Pin	2
11	200002	Left Pump Control Rod	1
	20214	Yoke	1
	N-105	5/16"-24 Hex Nut	1
12	W-110	1/2" Machinery Bushing	4
13	20252	Spring	2
14	N-175	1/2"-13 Coupling Nut	2
15	B-138	1/2"-13x1" Bolt	2
16	68142	Plastic Plug 1"x1"	2
17	67256	Plastic Plug 1"x2"	2
18	20223	Spring Backing Clip	2

DIXIE CHOPPER

TRANSMISSION & DRIVE FOR XT2800EFI & XT3000

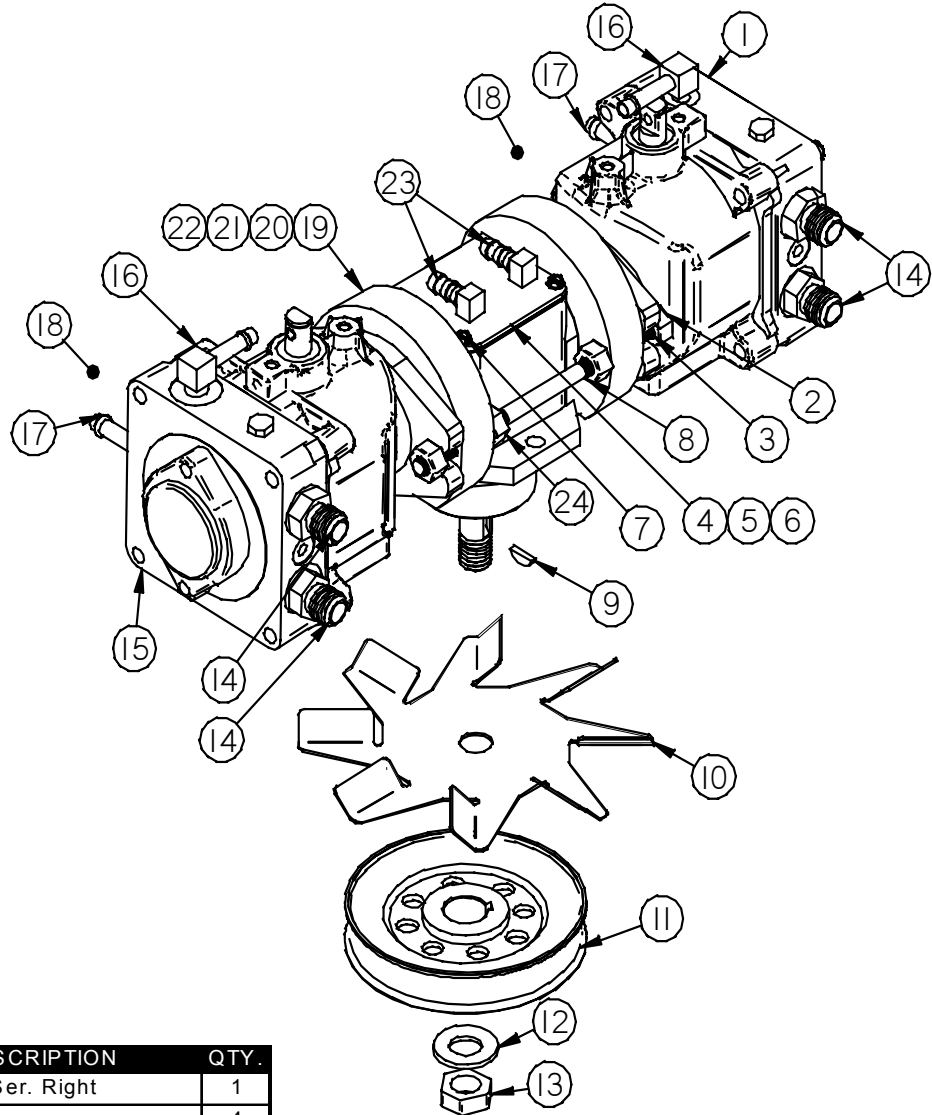

REF #	PART #	DESCRIPTION	QTY.
1	200012	Pump -16 Ser. Right	1
2	N-168	3/8"-24 Nut	4
3	W-169	5/16" Grade 8 Flat Washer	4
4	000365201-L	T-Gear Box (Complete Gear Box Only)	1
5	788101	T-Box Gasket	1
6	772150	T-Box Cover Plate	1
7	792025	T-Box Cover Plate Bolt	4
8	65206	3/8" Threaded Rod	2
9	K-102	Woodruff Key 3/16"x3/4"	1
10	200040	Fan - 8 1/8"	1
11	200041	Transmission Pulley 5 1/4"	1
12	W-132	3/4" Belleville Washer	1
13	N-114	3/4"-16 Nut	1
14	65004	High Pressure Port Fitting	4

REF #	PART #	DESCRIPTION	QTY.
15	200013	Pump -16 Ser. Left	1
16	67015	Case Bleed Fitting	2
17	72016	Straight 1/2"x1/2" Fitting	2
18	2513030	Dump Valve - No Cross Port	2
19	200003	Bell Housing - 16 Ser. Pump	2
20	788030B	Bearing Plate Gasket	2
21	792026	Bell Housing Bolt	8
22	65024	Pump O Ring	2
23	68031	T-Box Fitting (Brass) S/N 3043211 & After use one on Left side Only. Plug on Right side (28534).	2
24	N-184	3/8"-24 Nut	4

DIXIE CHOPPER

TRANSMISSION & DRIVE FOR XXW4600

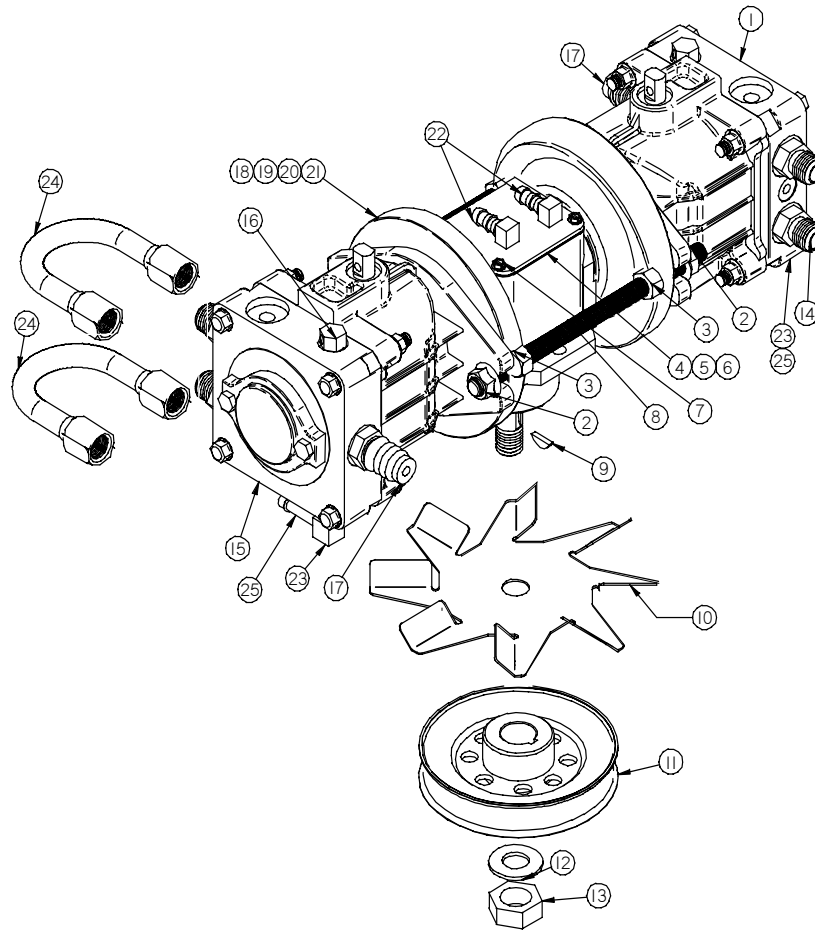

REF #	PART #	DESCRIPTION	QTY.
1	991168006	Pump - Twin Big Right	1
2	N-157	1/2"-13 Whiz Flange Nut	4
3	N-185	1/2"-13 Grade 8 STD. Nut	4
4	000365201-L	T Gear Box	1
5	788101	T Box Gasket	1
6	772150	T Box Cover Plate	1
7	792025	T Box Cover Plate Bolt	4
8	72206	1/2" Threaded Rod	2
9	K-102	Woodruff Key 3/16"x 3/4"	1
10	200040	Fan - 8 1/8"	1
11	200041	Transmission Pulley - 5 1/4"	1
12	W-132	3/4" Belleville Washer	1
13	N-114	Nut - 3/4"-16	1

REF #	PART #	DESCRIPTION	QTY.
14	65004	High Pressure Port Fitting	4
15	991168005	Pump - Twin Big Left	1
16	25-130-30	Dump Valve	2
17	72016	Fitting	2
18	72024	Bell Housing O-Ring	2
19	72001	Big Bell Housing	2
20	788030B	Bearing Plate Gasket	2
21	792026	Bell Housing Bolt	8
22	68031	T-Box Fitting (Brass) <i>S/N 3043211 & After use one Left side Only. Plug on Right side (28534).</i>	2
23	72021	1/2"x3/8" 90 Fitting	2
24	68010	U-Tube Steel Line	2
25	60124	3/8" Hose Clamp	2

DIXIE CHOPPER

18 Cu. In. WHEEL MOTOR

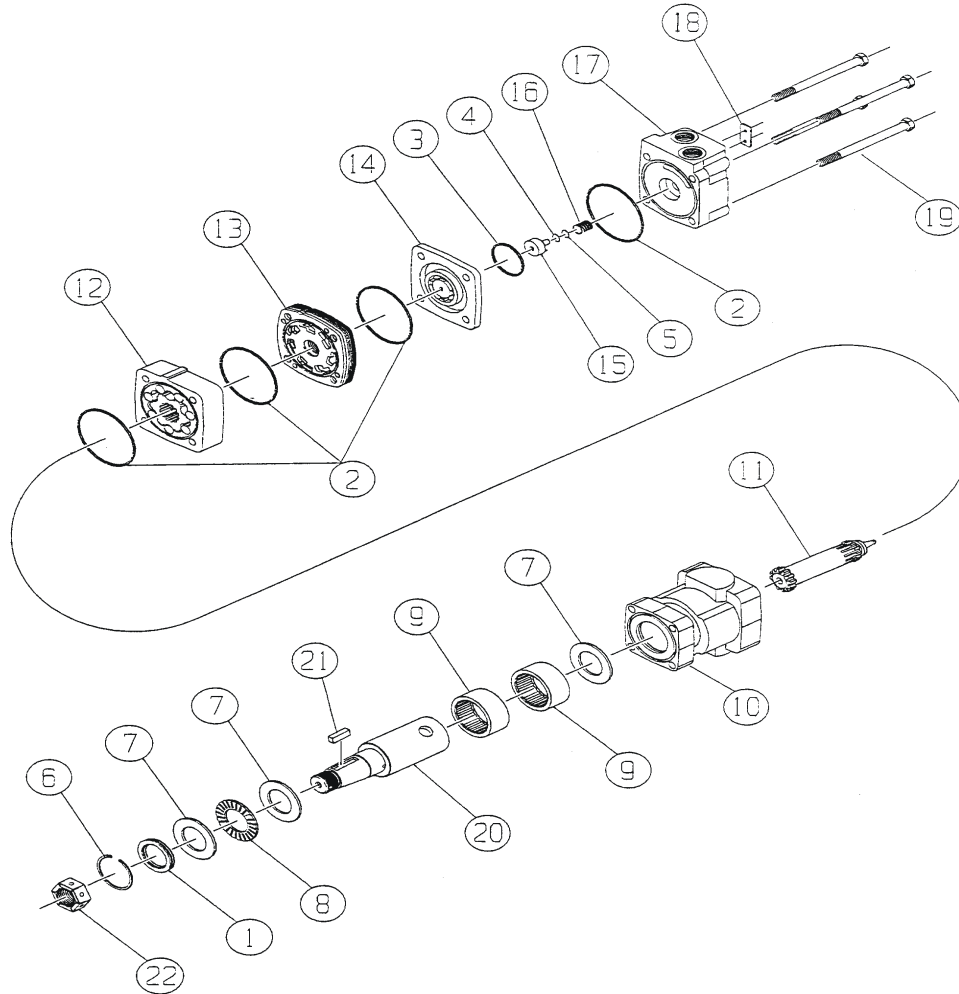

REF #	PART #	DESCRIPTION	QTY.
	67118-W	Complete 18 Cu. In. Wheel Motor Identification # W80380	2
	PB333700	Seal Kit (Contains item 1-5)	
1	PB018069	Dust/Shaft Seal	1
2	IN KIT	Body Seal	4
3	IN KIT	Commutator Seal	1
4	IN KIT	O-ring Seal	1
5	IN KIT	Teflon Back-up Seal	1
6	PB018073	Snap Ring	1
7	PB018054	Thrust Washer	3
8	PB018052	Thrust Bearing	1
9	PB018053	Housing Bearing	2
10	PB130015	Housing	1

REF #	PART #	DESCRIPTION	QTY.
11	PB014027	Drive Link (18 cu.in.)	1
12	PB332018	Rotor Assembly (18 cu.in.)	1
13	PB015008	Manifold	1
14	PB012013	Commutator Assembly 18 Cu. In.	1
15	PB018056	Endcover Piston	1
16	PB018059	Piston Spring	1
17	PB160007G	Endcover	1
18	N/A	ID Tag	1
19	PB334018	Assembly Bolts (18 cu.in.)	4
20	PW72545	Shaft	1
21	PW72546	Shaft Key	1
22	PB339303P	Shaft Nut	1

DIXIE CHOPPER

24 Cu. In. Wheel Motor

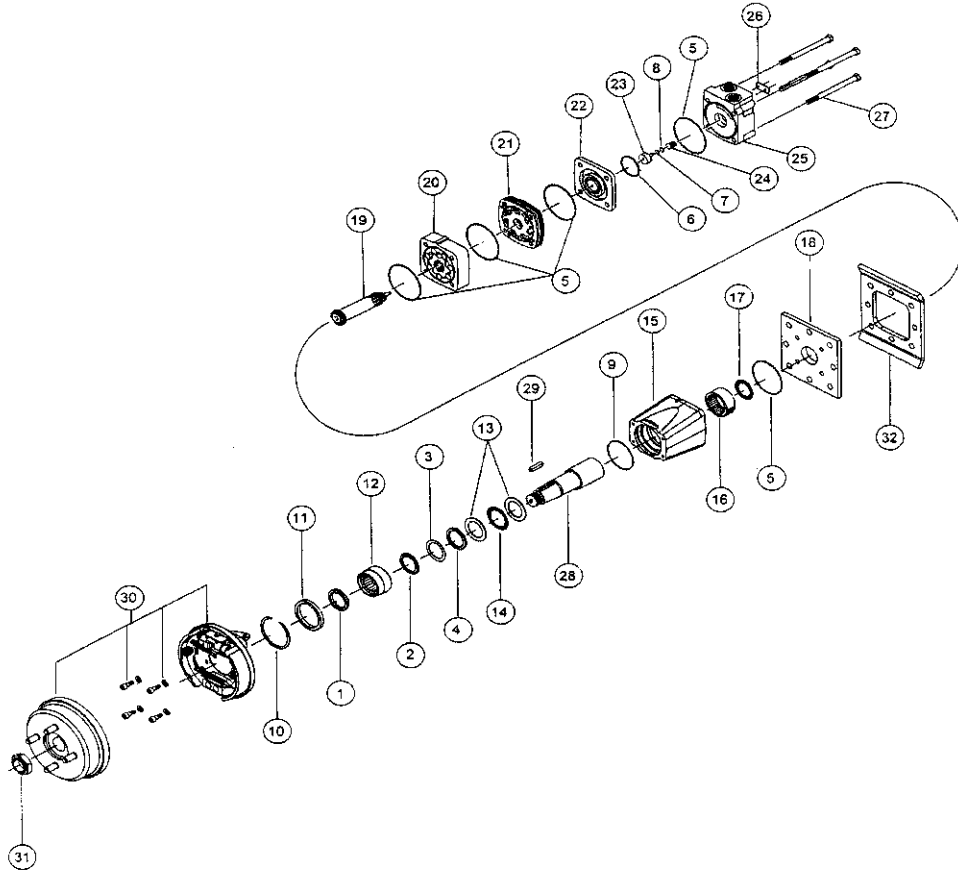

REF #	PART #	DESCRIPTION	QTY.
	200024	24 Cu. In. Wheel Motor w/Brake System	2
	300333850	Seal Kit - Contains Items 1-9	
1	In-Kit	Dust Seal	1
2	In-Kit	Metal Back Up Ring	1
3	In-Kit	Back Up Seal	1
4	In-Kit	Shaft Seal	1
5	In-Kit	Body Seal	5
6	In-Kit	Commutator Seal	1
7	In-Kit	O-Ring Seal	1
8	In-Kit	Back Up Seal	1
9	In-Kit	Housing Seal	1
10	700018013	Retaining Ring	1
11	700018085	Bearing Spacer	1
12	300018021	Front Housing Bearing	1
13	300018002	Thrust Washer	2
14	300018003	Front Thrust Bearing	1
15	300130035	"35" Housing	1

REF #	PART #	DESCRIPTION	QTY.
16	500018003	Rear Housing Bearing	1
17	300018107	Rear Thrust Bearing	1
18	300012016	Mid Mount Plate	1
19	300014031	24 Drive Link	1
20	300332024	24 Rotor Set	1
21	300015008	Manifold	1
22	300012013	Commutator Assembly	1
23	300018056	Piston	1
24	300018059	Piston Spring	1
25	300160007G	Endcover	1
26	N/A	"Not Orderable"	1
27	300335024	24 Rotor Bolts	7
28	300110051	Shaft	1
29	300339102	Shaft Key	1
30	300018105WHAZ	Brake Kit	1
31	PW72693	Lock Nut	1
32	200016	Wheel Motor Bracket Face Plate (Face Plate Comes With Frame)	

DIXIE CHOPPER

XT2800EFI & XT3000 HYDRAULIC HOSE DIAGRAM

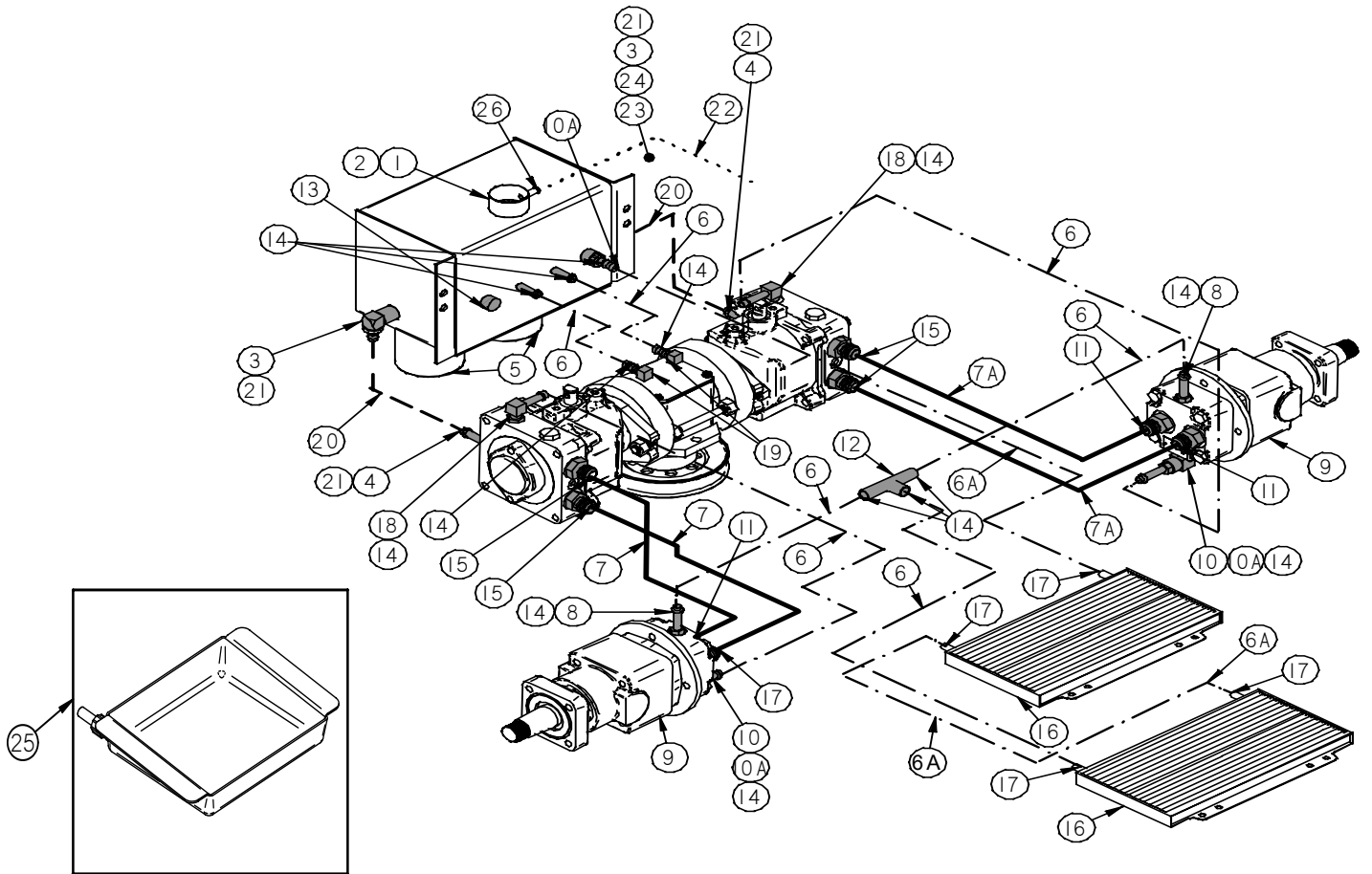

REF #	PART #	DESCRIPTION	QTY.
1	200008	Hydraulic Tank and Cap	1
2	40117-C 40117-T	Oil Cap T - Handle Cap w/Dipstick (Optional)	
3	72015	90 Deg. 3/8"x1/2" Fitting	2
4	72016	Straight 1/2"x1/2" Fitting	2
5	68140	Filter - Hydro Zinga 40 Micron	2
6	65108	3/8" Clear Hose	/ft.
6A	60109	3/8" Black Hose	/ft.
7	65074	High Pressure Black Hydro Hose Left	2
7A	65075	High Pressure Black Hydro Hose Right	2
8	67016	1/4" O-Ring x3/8" Barb Fiting	2
9	67118-W	Wheel Motor - 18 Cubic In. (XT2800EFI, XT3000)	2
10	67017	90 - Degree Fitting	2
10A	67014	Brass Fitting	3
11	87104	Steel Fitting	4

REF #	PART #	DESCRIPTION	QTY.
12	67008	3/8" Tee	1
13	65009	3/8" Pipe Plug	1
14	67013	Clamps For 65018 Hose (Green)	14
15	65004	High Pressure Port Fitting	4
16	60103-L	Oil Cooler	2
17	68231	#4 Micro Hose Clamp	4
18	67015	90 Degree Fitting	2
19	68031	T-Box Fitting (Brass)	2
20	200025	1/2"ID.x3/4"OD. Black Braided Hose (Exterior Braided)	/ft.
21	97098	1/2" Clamp	4
22	97374	5/16" Black Hose	/ft.
23	60115	Fitting - 3/8" Close Nipple	1
24	200023	Fitting - 3/8" Pipe Coupler	1
25	900018	Optional - Drain Pan for Hydro Filter	
26	72012	Black Clamp	1

DIXIE CHOPPER

XT2800EFI & XT3000 HYDRAULIC HOSE DIAGRAM SERIAL NUMBER 3043211 & AFTER

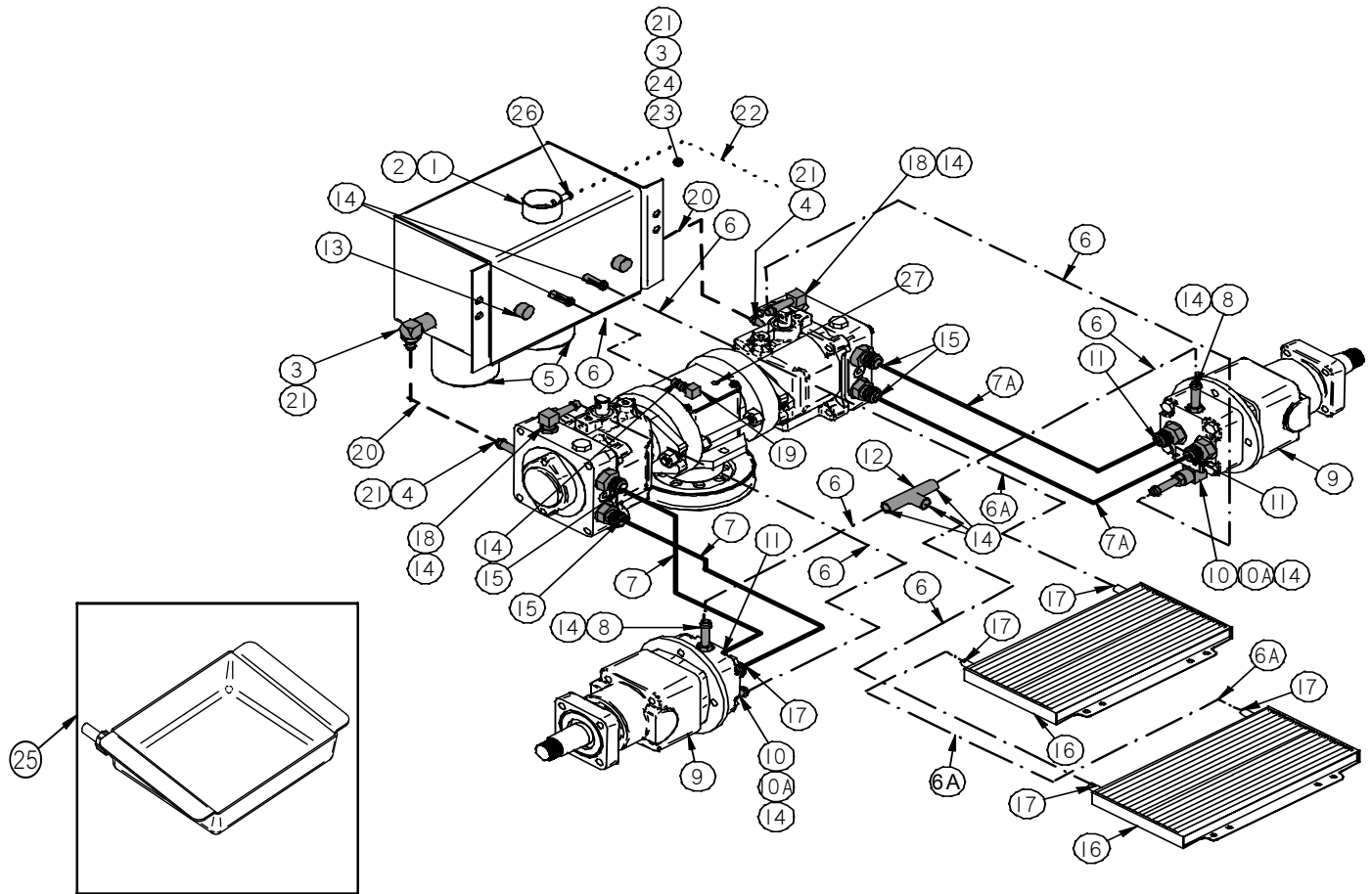

REF #	PART #	DESCRIPTION	QTY.
1	20008	Hydraulic Tank and Cap	1
2	40117-C 40117-T	Oil Cap T - Handle Cap w/Dipstick (Optional)	
3	72015	90 Deg. 3/8"x1/2" Fitting	2
4	72016	Straight 1/2"x1/2" Fitting	2
5	68140	Filter - Hydro Zinga 40 Micron	2
6	65108	3/8" Clear Hose	/ft.
6A	60109	3/8" Black Hose	/ft.
7	65074	High Pressure Black Hydro Hose Left	2
7A	65075	High Pressure Black Hydro Hose Right	2
8	67016	1/4" O-Ring x3/8" Barb Fitting	2
9	67118-W	Wheel Motor - 18 Cubic In. (XT2800EFI, XT3000)	2
10	67017	90 - Degree Fitting	2
10A	67014	Brass Fitting	2
11	87104	Steel Fitting	4

REF #	PART #	DESCRIPTION	QTY.
12	67008	3/8" Tee	1
13	65009	3/8" Pipe Plug	1
14	67013	Clamps For 65018 Hose (Green)	12
15	65004	High Pressure Port Fitting	4
16	60103-L	Oil Cooler	2
17	68231	#4 Micro Hose Clamp	4
18	67015	90 Degree Fitting	2
19	68031	T-Box Fitting (Brass)	1
20	200025	1/2"ID.x3/4"OD. Black Braided Hose (Exterior Braided)	/ft.
21	97098	1/2" Clamp	4
22	97374	5/16" Black Hose	/ft.
23	60115	Fitting - 3/8" Close Nipple	1
24	200023	Fitting - 3/8" Pipe Coupler	1
25	900018	Optional - Drain Pan for Hydro Filter	
26	72012	Black Clamp	1
27	28534	T-Box Plug	1

DIXIE CHOPPER

XXW4600 HYDRAULIC HOSE DIAGRAM

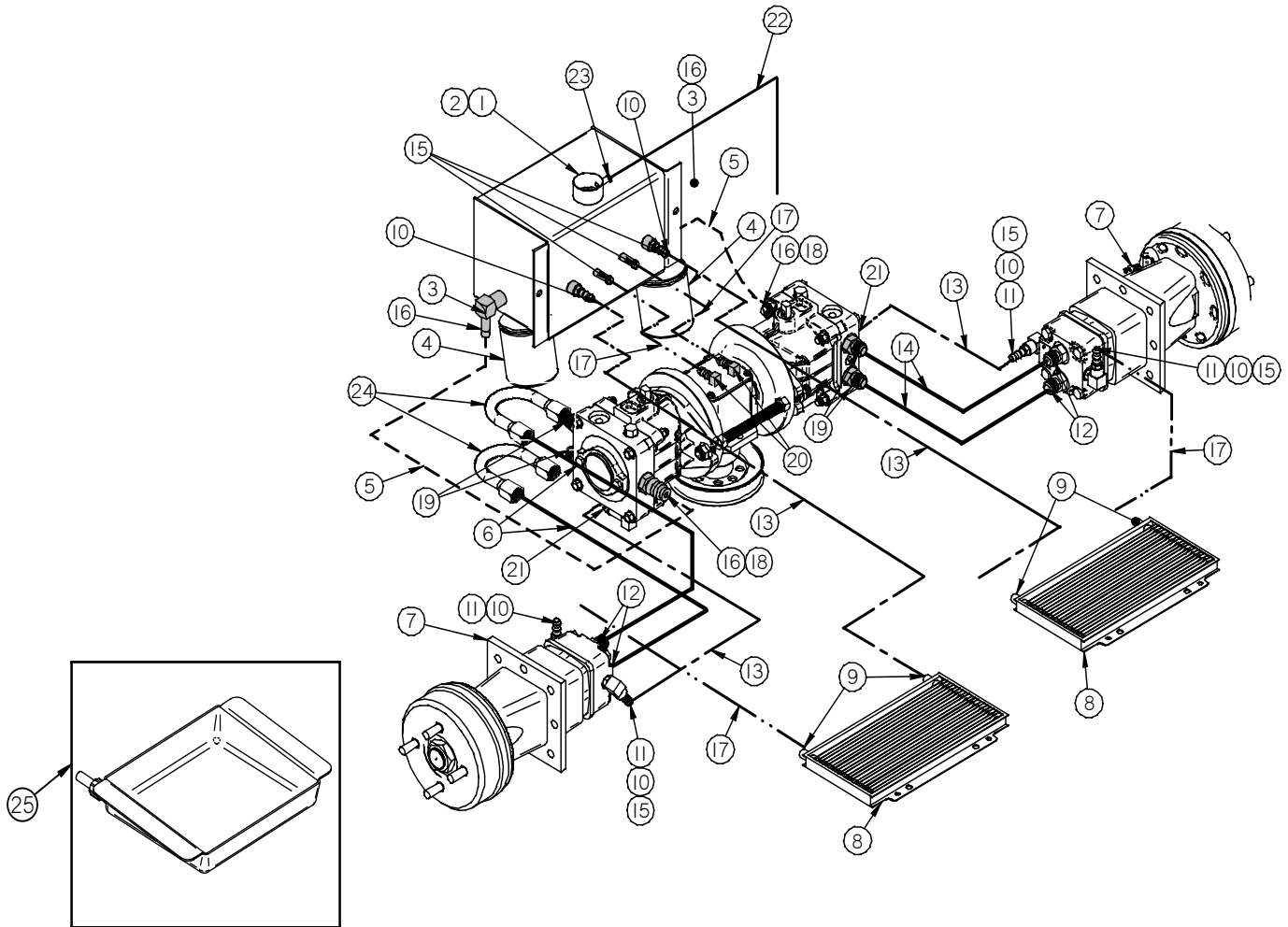

REF #	PART #	DESCRIPTION	QTY.
1	200008	Hydraulic Tank (3-1-02) w/ cap	1
2	40117-C	Oil Tank cap	
3	72015	Fitting - 90 Deg. 3/8" x 1/2"	2
4	68140	Filter - Hydro Zinga 40 Micron	2
5	200025	1/2" Black Braided Hose	/ft.
6	200015	High Pressure Black Hydro Hose	2
7	200024	Wheel Motor - 24 Cu. In. (XXW4600)	2
8	60103-L	Oil Cooler	2
9	68231	Worm Clamp	4
10	67014	3/8" barb x 1/4" MPT Fitting	6
11	67017	90 degree fitting	4
12	87104	Steel Fitting	4

REF #	PART #	DESCRIPTION	QTY.
13	60109	3/8" Black Hose	/ft.
14	65075	High Pressure Black Hydro Hose	2
15	67013	Clamps for 65108 (Green)	10
16	68233	#8 Worm Clamp	4
17	65108	3/8" Clear Hose	/ft.
18	72021	Straight 1/2"x1/2" Fitting	2
19	65004	High Pressure Port Fitting	4
20	68031	T-Box Fitting (Brass)	2
21	72021	1/2"x3/8" 90 Deg. Fitting	2
22	97374	5/16" Black Hose	/ft.
23	72012	5/16" Black Clamp	1
24	68010	U-Tube Steel Line	2
25	900018	Oil Pan Tray (Optional)	

DIXIE CHOPPER

XXW4600 HYDRAULIC HOSE DIAGRAM SERIAL NUMBER 3043211 & AFTER

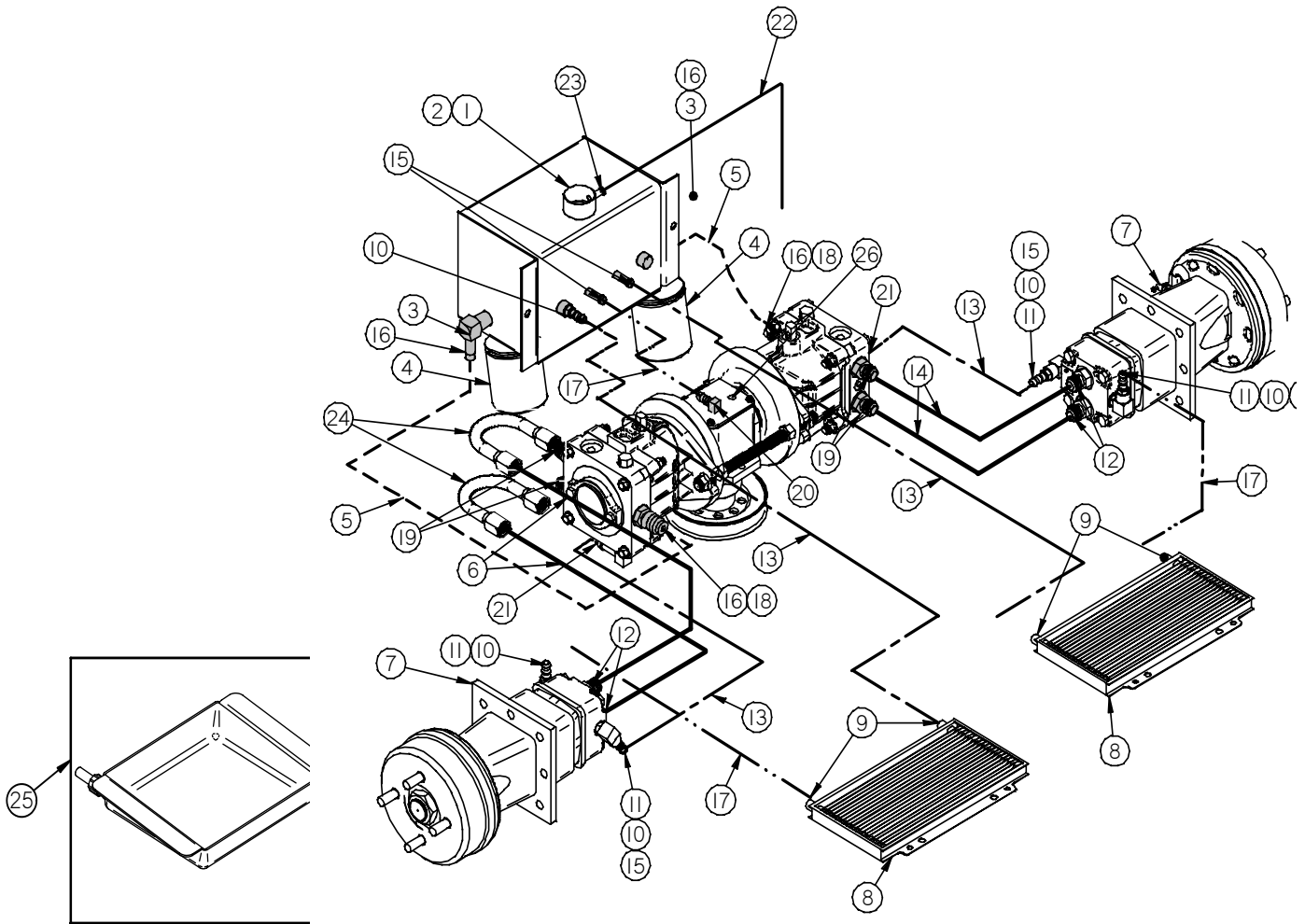

REF #	PART #	DESCRIPTION	QTY.	REF #	PART #	DESCRIPTION	QTY.
1	200008	Hydraulic Tank (3-1-02) w/ cap	1	14	65075	High Pressure Black Hydro Hose	2
2	40117-C	Oil Tank cap		15	67013	Clamps for 65108 (Green)	10
3	72015	Fitting - 90 Deg. 3/8" x 1/2"	2	16	68233	#8 Worm Clamp	4
4	68140	Filter - Hydro Zinga 40 Micron	2	17	65108	3/8" Clear Hose	/ft.
5	200025	1/2" Black Braided Hose	/ft.	18	72021	Straight 1/2"x1/2" Fitting	2
6	200015	High Pressure Black Hydro Hose	2	19	65004	High Pressure Port Fitting	4
7	200024	Wheel Motor - 24 Cu. In. (XXW4600)	2	20	68031	T-Box Fitting (Brass)	2
8	60103-L	Oil Cooler	2	21	72021	1/2"x3/8" 90 Deg. Fitting	2
9	68231	Worm Clamp	4	22	97374	5/16" Black Hose	/ft.
10	67014	3/8" barb x 1/4" MPT Fitting	6	23	72012	5/16" Black Clamp	1
11	67017	90 degree fitting	4	24	68010	U-Tube Steel Line	2
12	87104	Steel Fitting	4	25	900018	Oil Pan Tray (Optional)	
13	60109	3/8" Black Hose	/ft.	26	28534	T-Box Plug	1

DIXIE CHOPPER

XT3000 FUEL SYSTEM

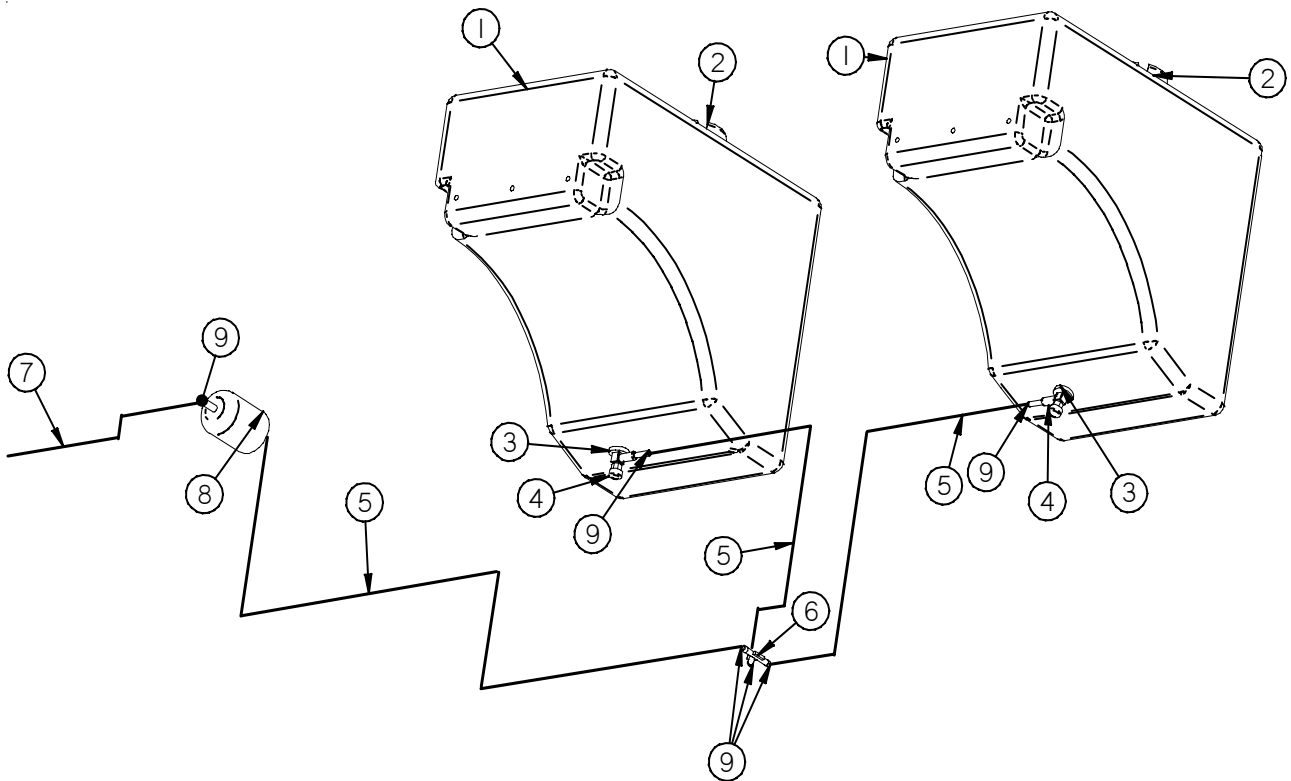

REF #	PART #	DESCRIPTION	QTY.	REF #	PART #	DESCRIPTION	QTY.
1	400015	7 Gal. Fuel Tank	2	5	97374	Gas Line - 5/16"	/ft.
2	600035	Fuel Cap	2	6	65008	Gas Line "T" - 5/16"	1
	40117-1	Fuel Cap - Manual Vent w/Gauge (Optional)		7	68231	Hose Clamp	1
3	40220	Fuel Tank Bushing	2	8	97392	Filter - Gas & Water Parker	1
4	400016	Valve - Fuel Tank Shut-Off	2	9	72012	Spring Clamp (Black)	7

DIXIE CHOPPER

XT2800EFI FUEL SYSTEM

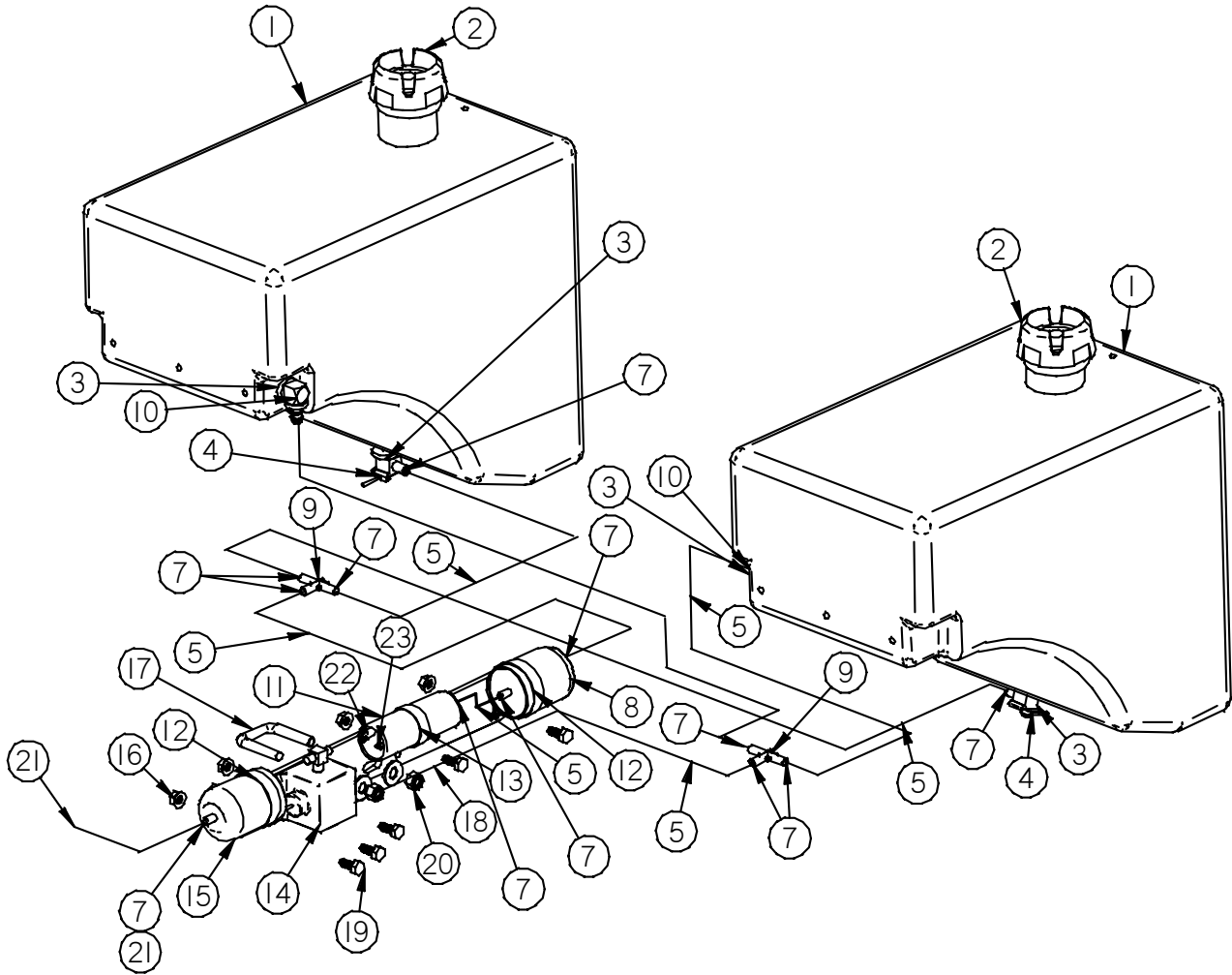

REF #	PART #	DESCRIPTION	QTY.
1	400015	7 Gal. Fuel Tank	2
2	600035	Fuel Cap	2
	40117-1	Fuel Cap - Manual Vent w/Guage (Optional)	
3	40220	Fuel Tank Bushing	4
4	400016	Valve - Fuel Tank Shut-Off	2
5	97374	Gas Line - 5/16"	/ft.
6			
7	72012	Hose Clamp (Black)	13
8	97392	Filter - Gas & Water Parker	1
9	65008	Gas Line "T" - 5/16"	2
10	72218	Elbow Gas Tank 5/16"	2
11	N/A	Kohler Part - (Pump)	1

REF #	PART #	DESCRIPTION	QTY.
12	C-108	Clamp	2
13	C-110	Clamp	1
14	N/A	Kohler Part - (Regulator)	1
15	N/A	Kohler Part - (Filter)	1
16	N-102	1/4"-20 Whiz Flange Nut	5
17	B-206	3/8"-16x1 3/8" w 2"L SQ U-Bolt	1
18	W-104	3/8" Flat Washer	2
19	B-102	1/4"-20x3/4" Bolt	5
20	N-107	3/8"-16 Nylon Locknut	2
21	600029	Clamp	7
22	500005	Ground Wire - (F/Fuel P.)	1
23	N-182	Nut (For Fuel Pump)	2

DIXIE CHOPPER

XXW4600-72 FUEL SYSTEM

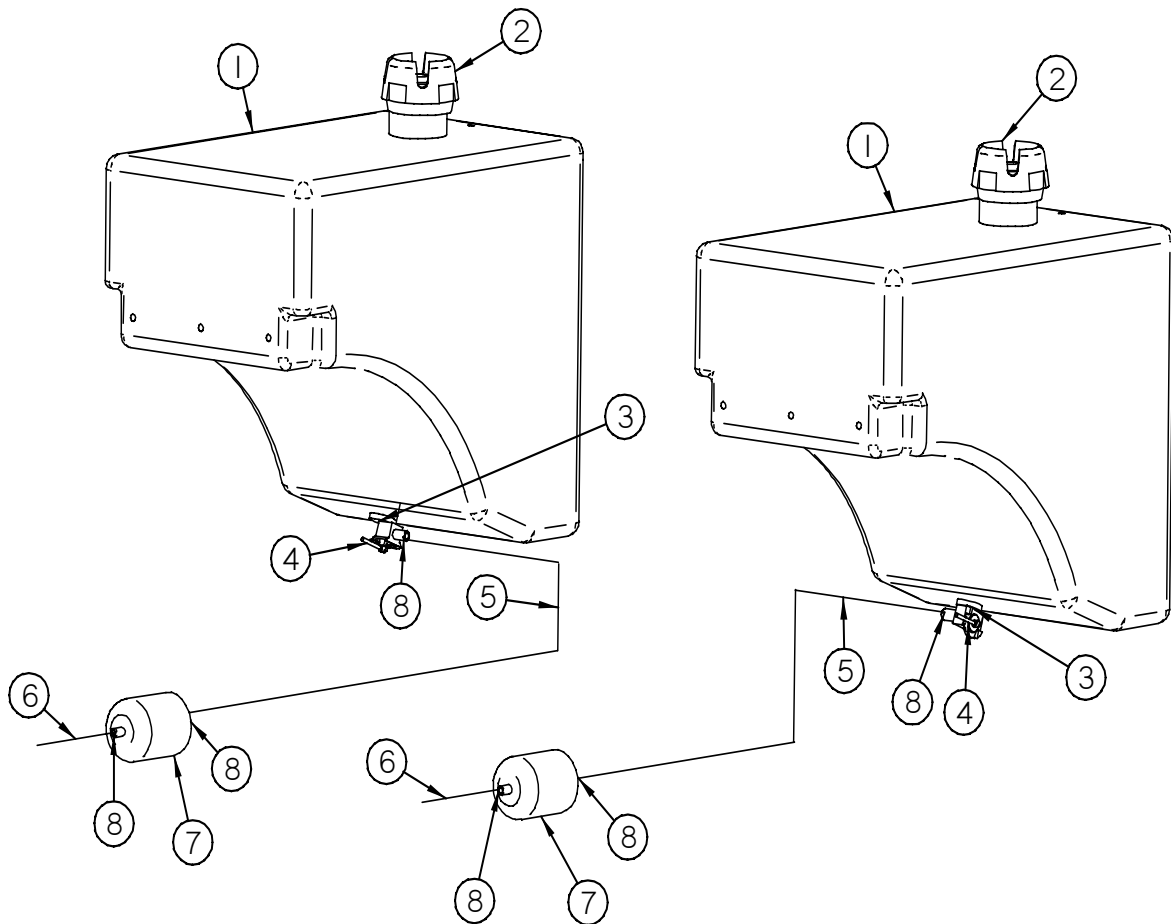

REF #	PART #	DESCRIPTION	QTY.
1	400015	7 Gal. Fuel Tank	2
2	600035	Fuel Cap	2
	40117-1	Fuel Cap - Manual Vent w/Guage (Optional)	
3	40220	Fuel Tank Bushing	2
4	400016	Valve - Fuel Tank Shut-Off	2

REF #	PART #	DESCRIPTION	QTY.
5	97374	Gas Line - 5/16"	/ft.
6	68231	Hose Clamp	2
7	97392	Filter - Gas & Water Parker	2
8	72012	Spring Clamp (Black)	6

DIXIE CHOPPER

XT2800EFI & XT3000 THROTTLE ASSEMBLY

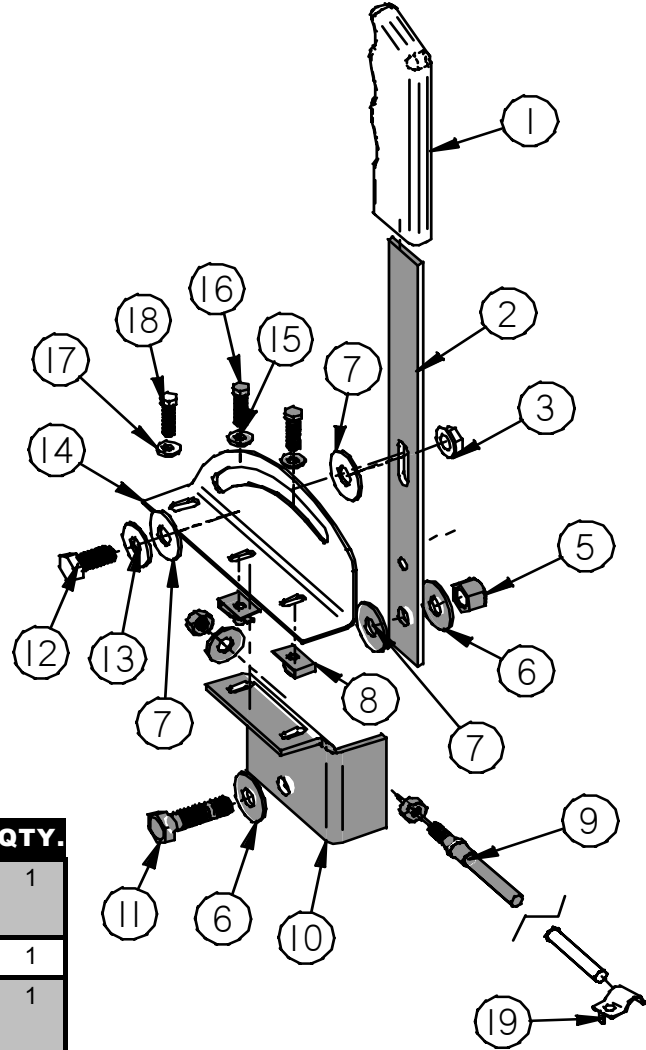
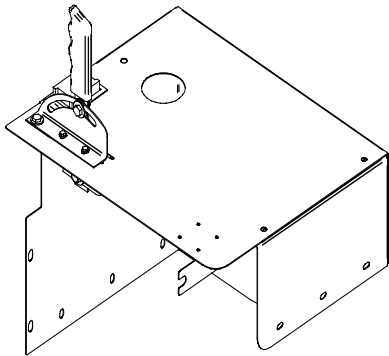

REF #	PART #	DESCRIPTION	QTY.
	68250	Complete Throttle Assembly F/ Kohler & Generac 2,5 - 11,15,16	1
1	67258	Handle Grip (Black)	1
2	97012	Offset Throttle Handle (Prior To S/N 3042437)	1
	600062	Handle - Throttle F/all Models (S/N 3042437)	1
3	N-134	5/16" Flange Lock Nut	1
5	N-107	3/8" -16 Nyloc Nut	1
6	W-104	3/8" Standard Flat Washer	2
7	W-125	3/8" Nylon Washer	3
8	C-105	C Clip	2
9	68249	Cable (New Style)	1
		Washer	2
		Hex Nut	2
		Cable and Liner	
	68249-K	Throttle Handle & Cable Kit (For 2003 & Older)	1

REF #	PART #	DESCRIPTION	QTY.
10	97011	Lower Throttle Mounting Bracket	1
11	B-108	3/8"-16 x1" Bolt	1
12	B-107	5/16"-18 x 3/4" Bolt	1
13	W-113	5/16" Flat Washer	1
14	65270	Upper Stainless Throttle Bracket	1
15	W-152	#10 Stainless Washer	2
16	B-203	10-24x3/4" Stainless Bolt	2
17	W-153	1/4" Stainless Flat Washer	1
18	B-209	1/4"-20x3/4" Bolt	1
19	C-107	Clamp - Kohler	1
		Generac	2

DIXIE CHOPPER

XXW4600 THROTTLE ASSEMBLY

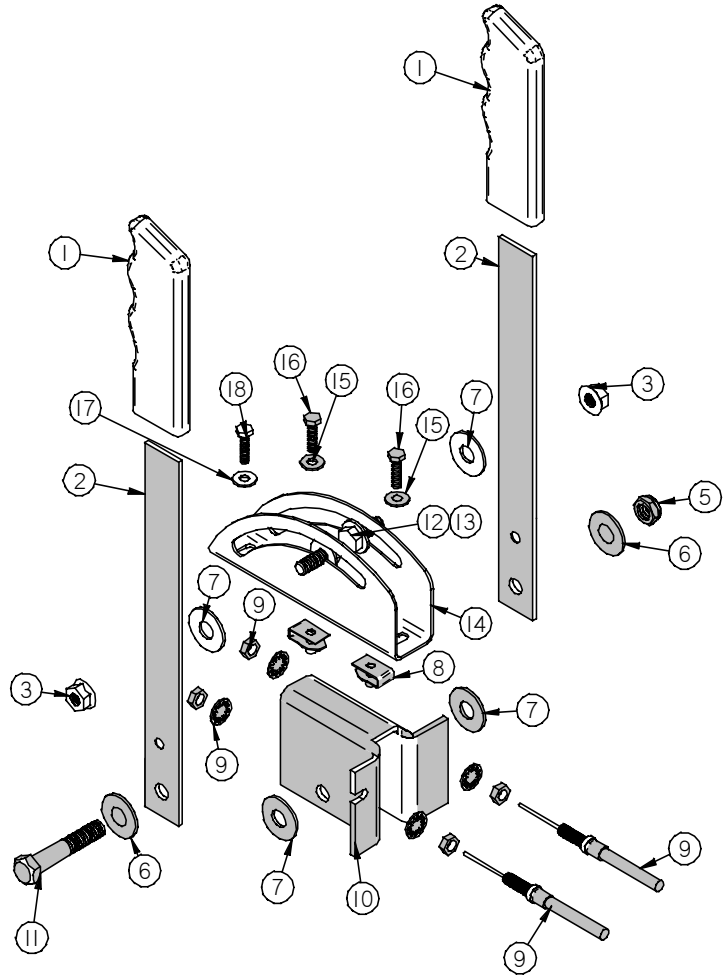
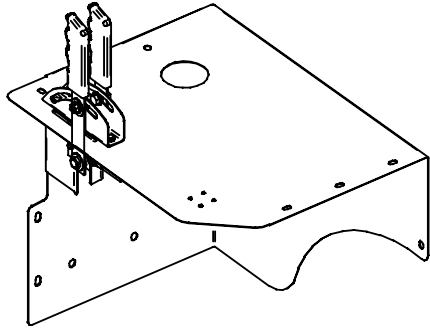

REF #	PART #	DESCRIPTION	QTY.
	68251	Complete Throttle Assembly 2,5-11,15-16	1
1	67258	Handle Grip (Black)	2
2	97012	Offset Throttle Handle (Prior to S/N 3042437)	2
	600062	Handle - Throttle F/all Models (S/N 3042437)	2
3	N-134	5/16" Flange Lock Nut	2
5	N-107	3/8" -16 Nyloc Nut	1
6	W-104	3/8" Standard Flat Washer	2
7	W-125	3/8" Nylon Washer	4
8	C-105	C Clip	2
9	68249	Cable (New Style)	2
		Washer	4
		Hex Nut	4
		Cable	2
	68249-K	Throttle Handle & Cable Kit (For 2003 & Older)	1

REF #	PART #	DESCRIPTION	QTY.
10	97010	Lower Throttle Mounting Bracket	1
11	B-165	3/8"-16x2" Hex Head Bolt	1
12	B-107	5/16"-18x3/4" Bolt	2
13	W-113	5/16" Flat Washer	2
14	68271	Upper Stainless Throttle Bracket	1
15	W-152	#10 Stainless Washer	2
16	B-203	10-24x3/4" Stainless Bolt	2
17	W-153	1/4" Stainless Flat Washer	1
18	B-209	1/4"-20x3/4" Bolt	1

DIXIE CHOPPER

XT2800EFI & XT3000 BODY

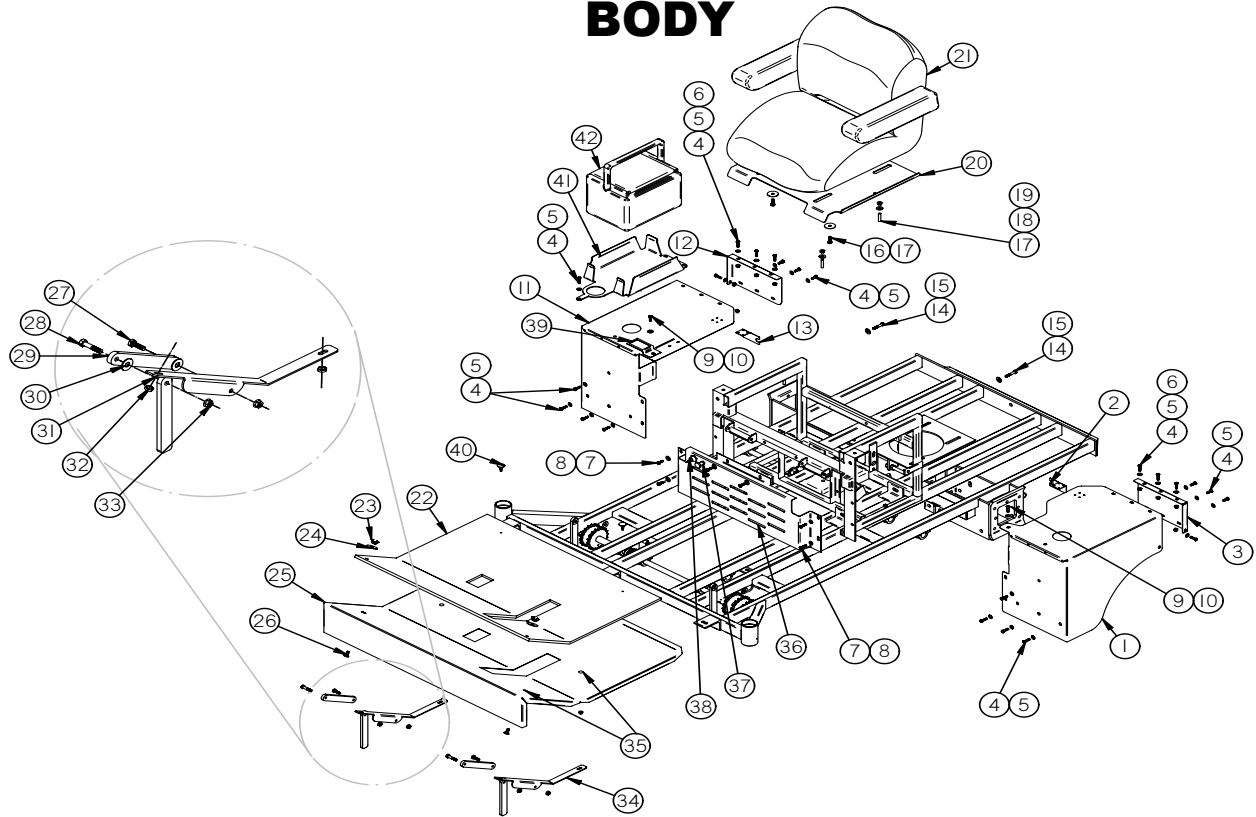

REF #	PART #	DESCRIPTION	QTY.
1	400003	Fender - 7 Gal. Low Ride Left	1
2	400035	Left Fender Mounting Tab	1
3	400033	Left Rear 7 Gal. Fuel Tank Support Bracket	1
4	B-103	1/4"-20 Stainless Bolt	24
5	W-153	1/4" Stainless Flat Washer	24
6	N-101	1/4"-20 Stainless Whiz Flange Nut	8
7	B-102	1/4"-20 Bolt	6
8	W-102	1/4" Flat Washer	6
9	B-209	1/4"-20X3/4" Stainless Bolt	2
10	W-153	1/4" Stainless Flat Washer	2
11	400004	Fender - 7 Gal. Low Ride Right	1
12	400034	Right Rear 7Gal. Fuel Tank Support Bracket	1
13	400036	Right Fender Mounting Tab	1
14	B-105	5/16"-18x1.75" Bolt	2
15	W-113	5/16" Flat Washer	4
16	B-131	5/16"-18x1 Bolt	2
17	W-118	5/16"x1.5" Fender Washer	4
18	S-115	5/16"-18x1.75" Stud	2
19	N-103W	5/16"-18 Hex Nut	4
20	400026	Seat Pan	1
21	40100-W	Seat (Complete)	1
	176801	Armrest Kit (L & R)	
	176803	Left Arm	
	176802	Right Arm	
	176201	Arm Pad (L or R)	

REF #	PART #	DESCRIPTION	QTY.
	306025	Back Cover	
	305839	Cushion Cover	
	177827PS	Springs Kit	
	400078	Gee- Ride - Seat Cover Back	
22	20275	Grey Carpet	1
23	N-106	Wing Nut	2
24	W-106	Washer	2
25	68272	Floor Pan	1
26	B-104	Carriage Bolt	2
27	B-131	5/16"-18x1" Bolt	2
28	B-171	5/16"-18x1.5" Bolt	2
29	400007	Connecting Arm	2
30	W-125	3/8" Plastic Washer	4
31	400006	Floor Pan Mounting Bracket (Right)	1
32	N-176	1/4"-20 Nylon Lock Nut	4
33	N-131	5/16"-18 Nylon Lock Nut	4
34	400005	Floor Pan Mounting Bracket (Left)	1
35	B-157	1/4"-20x1/2" Carriage Bolt	4
36	400077	Front Panel	1
37	20248	Choke	1
38	20245	Ignition Switch	1
39	68247	Tachometer/Hourmeter Bracket	1
40	C-111	Plastic Cap For Floor Pan	2
41	400056	7 Gal. Cooler Kit (Optional)	1
42	400060	Cooler - Igloo Lunch	1

DIXIE CHOPPER

XXW4600 BODY

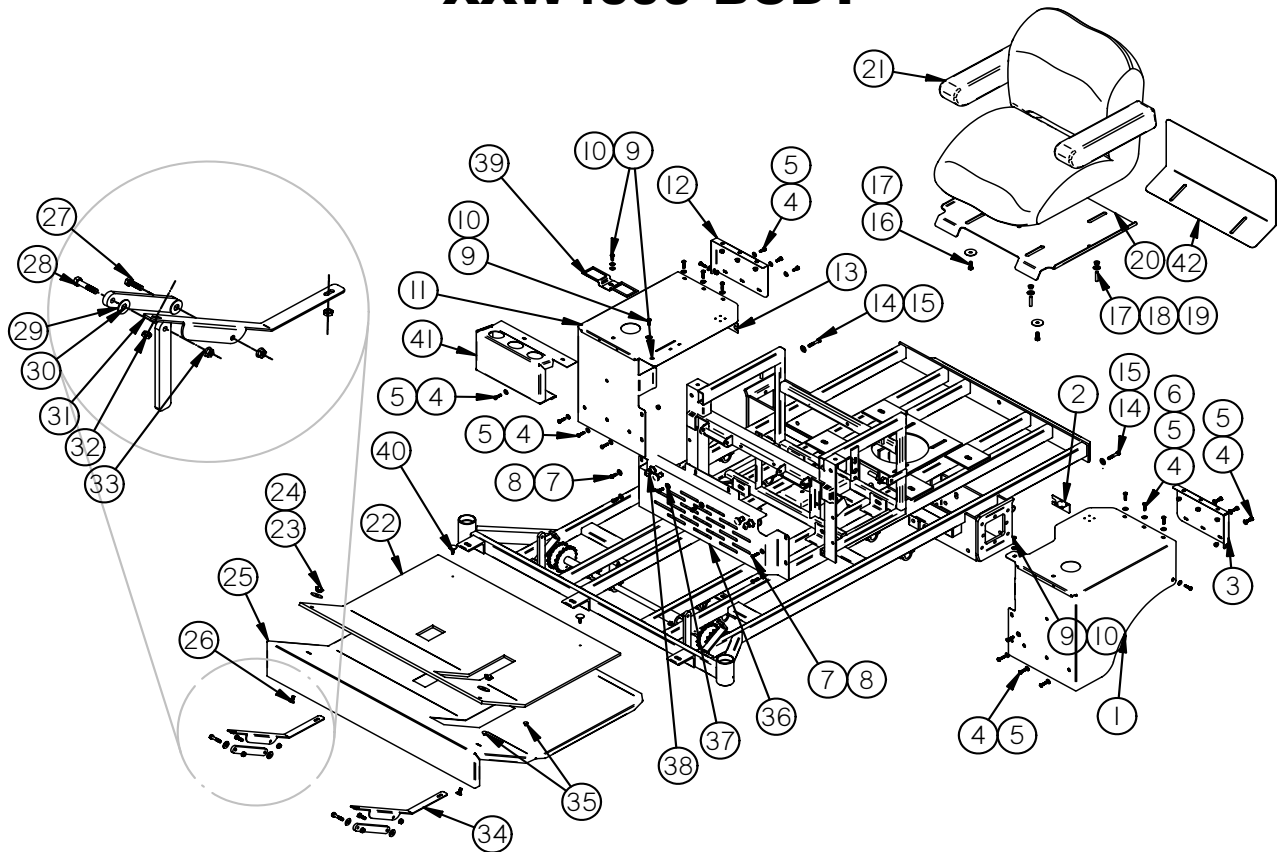

REF #	PART #	DESCRIPTION	QTY.
1	400003	Fender - 7 Gal. Low Ride Left	1
2	400035	Left Fender Mounting Bracket	1
3	400033	Left Rear 7 Gal. Fuel Tank Support Bracket	1
4	B-103	1/4"-20 Stainless Bolt	23
5	W-153	1/4" Stainless Flat Washer	22
6	N-101	1/4"-20 Stainless Whiz Flange Nut	8
7	B-102	1/4"-20 Bolt	6
8	W-102	1/4" Flat Washer	6
9	B-209	1/4"-20X3/4" Stainless Bolt	3
10	W-153	1/4" Stainless Flat Washer	4
11	400046	Fender - 7 Gal. Low Ride Right	1
12	400034	Right Rear 7Gal. Fuel Tank Support Bracket	1
13	400036	Right Fender Mounting Tab	1
14	B-105	5/16"-18x1.75" Bolt	2
15	W-113	5/16" Flat Washer	4
16	B-131	5/16"-18x1 Bolt	2
17	W-118	5/16"x1.5" Fender Washer	4
18	S-115	5/16"-18x1.75" Stud	2
19	N-103W	5/16"-18 Hex Nut	4
20	400026	Seat Pan	1
21	40100-W	Seat (Complete)	1
	176801	Armrest Kit (L & R)	
	176803	Left Arm	
	176802	Right Arm	
	176201	Arm Pad (L or R)	

REF #	PART #	DESCRIPTION	QTY.
	306025	Back Cover	
	305839	Cushion Cover	
	177827PS	Spring Kit	
	400078	Gee - Ride - Seat Cover Back	
22	20275	Grey Carpet	1
23	N-106	Wing Nut	2
24	W-106	Washer	2
25	400045	Floor Pan	1
26	B-104	Carriage Bolt	2
27	B-131	5/16"-18x1" Bolt	2
28	B-171	5/16"-18x1.5" Bolt	2
29	400007	Connecting Arm	2
30	W-125	3/8" Plastic Washer	4
31	400006	Floor Pan Mounting Bracket (Right)	1
32	N-176	1/4"-20 Nylon Lock Nut	4
33	N-131	5/16"-18 Nylon Lock Nut	4
34	400005	Floor Pan Mounting Bracket (Left)	1
35	B-157	1/4"-20x1/2" Carriage Bolt	4
36	400044	Front Panel	1
37	20248	Choke	2
38	20245	Ignition Switch	2
39	68247	Tachometer/Hourmeter Bracket	2
40	C-111	Plastic Cap	2
41	68248	Gauge Panel	1
42	400043	Heat Seat Guard	1

DIXIE CHOPPER

XT2800EFI & XT3000 BRAKE ASSEMBLY

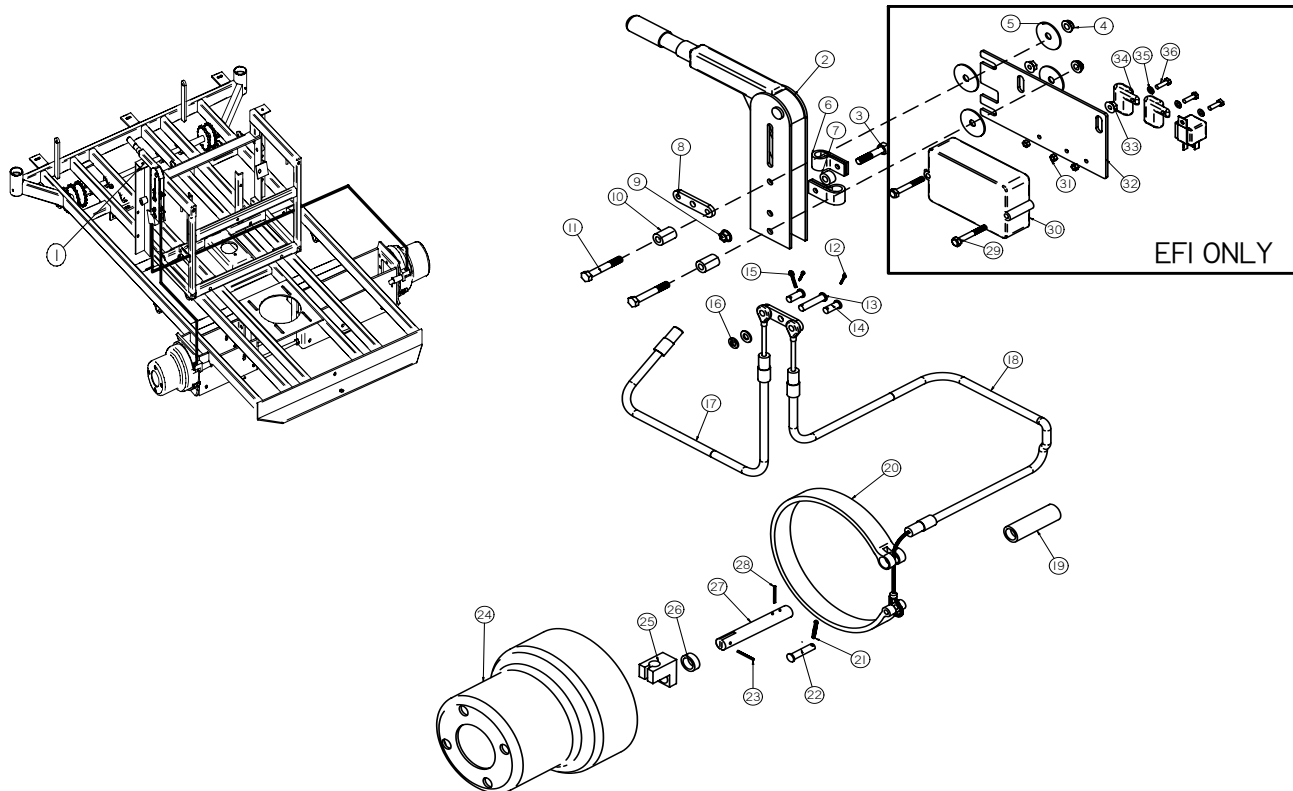

REF #	PART #	DESCRIPTION	QTY.
1	N/A	Complete Brake	1
2	97094	Brake Handle Assembly (Inc. #2 - #18)	1
3	N/A	Bolt	1
4	N-134	5/16"-18 Large Flange Nut	2
5	W-106	3/8" Washer	4
6	65061	R Clip	2
7	65063	Spacer	1
8	65060	Pivot Plate	2
9	N/A	Nut	1
10	65062	Spacer	2
11	B-156	5/16"-18x2" Bolt	2
12	N/A	Hairpin Cotter	2
13	P-129	5/16"x1 1/2" Clevis Pin	1
14	P-112	5/16"x3/4" Clevis Pin	2
15	N/A	Hairpin Cotter	1
16	W-102	1/4" Flat Washer	2
17	65247	Right Brake Cable (Long)	1
18	65246	Left Brake Cable (Short)	1
19	65277	Bushing (Welded on Frame)	2
20	65244	Brake Band	2

REF #	PART #	DESCRIPTION	QTY.
21	P-108	3/32"x1 1/2" Cotter Pin	2
22	P-107	5/16x1 1/4" Clevis Pin	2
23	P-118	3/16"x1 1/2" Roll Pin	2
24	67266	Brake Drum	2
25	991100025	Brake Cable Retainer	2
26	65284 65278 30112	Spacer - Use #65284 and #30112 or #65278 to place brake band fully onto brake drum.	
27	97409	Brake Pin	2
28	P-118	3/16"x1 1/2" Roll Pin	2
29	B-257	1/4"-20x1.75" Bolt	2
30	N/A	EFI Module	1
31	N-179	M5 -.8 Hex Locknut	3
32	600009	EFI Module Mount	1
33	N-102	1/4"-20 Whiz Nut	2
34	N/A	Fuse Holder	2
35	W-175	M5 Flat Washer	3
36	B-258	M5 - .8x16mm Bolt	3
37	N/A	Relay	1

DIXIE CHOPPER

XXW4600 BRAKE ASSEMBLY

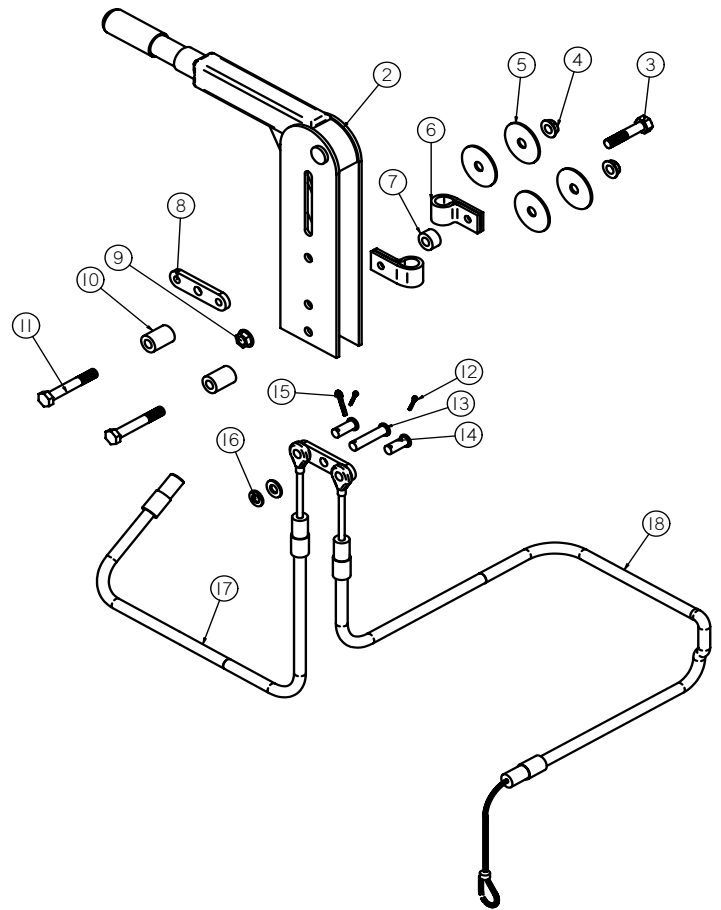
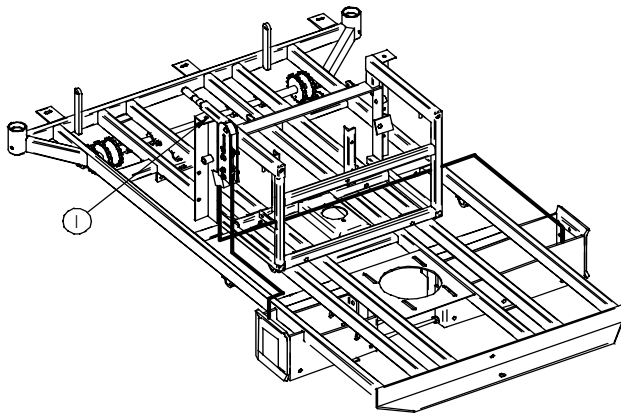

REF #	PART #	DESCRIPTION	QTY.
1	N/A	Complete Brake	1
2	97094	Brake Handle Assembly (Inc. #2 - #18)	1
3	N/A	Bolt	1
4	N-134	5/16"-18 Large Flange	2
5	W-106	3/8" Washer	4
6	65061	R Clip	2
7	65063	Spacer	1
8	65060	Pivot Plate	2
9	N/A	Nut	1

REF #	PART #	DESCRIPTION	QTY.
10	65062	Spacer	2
11	B-156	5/16"-18x2" Bolt	2
12	N/A	Hairpin Cotter	2
13	P-129	5/16"x1 1/2" Clevis Pin	1
14	P-112	5/16" X 3/4" Clevis Pin	2
15	N/A	Hairpin Cotter	1
16	W-102	1/4" Flat Washer	2
17	65247	Right Brake Cable (Long)	1
18	65246	Left Brake Cable (Short)	1

DIXIE CHOPPER

XXW4600 CENTER HUB ASSEMBLY

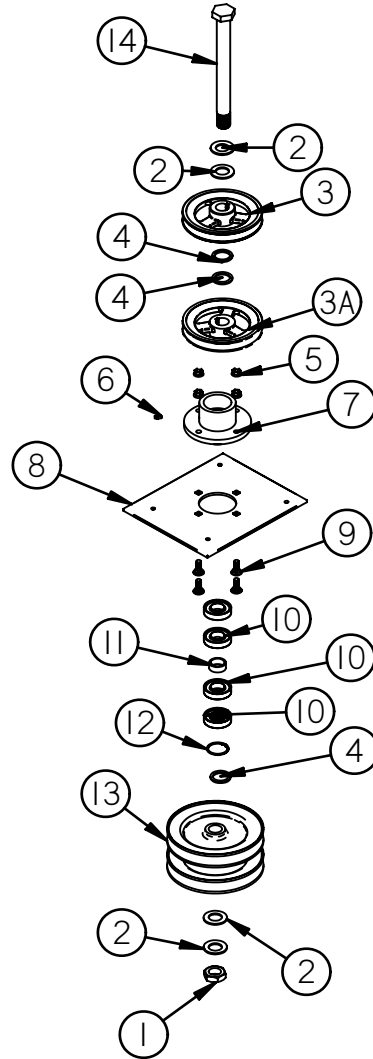
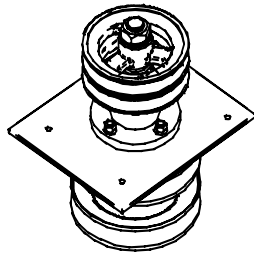

REF #	PART #	DESCRIPTION	QTY.
	68242	Center Drive Hub Assembly (#1 - #14)	
1	N-167	1"-14 Jam Nut	1
2	W-137	1"X2" Belleville Washer	4
3	68222	6" Cast Pulley	1
3A	68222TB	6" Cast Pulley	1
4	W-131	1" ID x 1 1/2" OD x 1/8" Thick	3
5	N-108	3/8"-16 Whiz Flange Nut	4
6	F-102	1/4"-28 Grease Fitting	1
7	68241	Trans Center Hub (Incl.-Ref. 7,10,11,12)	1

REF #	PART #	DESCRIPTION	QTY.
8	68111	Twin Hub Mounting Plate	1
9	B-135	3/8"-16x1" Carriage Bolt	4
10	30218	Bearing & Spacer	4
11	300022	Spacer 1/2" Machined	1
12	788080	Retainer Ring	1
13	9907600X600D	Center Drive Pulley	1
14	97388	Jackshaft	1

DIXIE CHOPPER

XXW4600 ENGINE POD ASSEMBLY

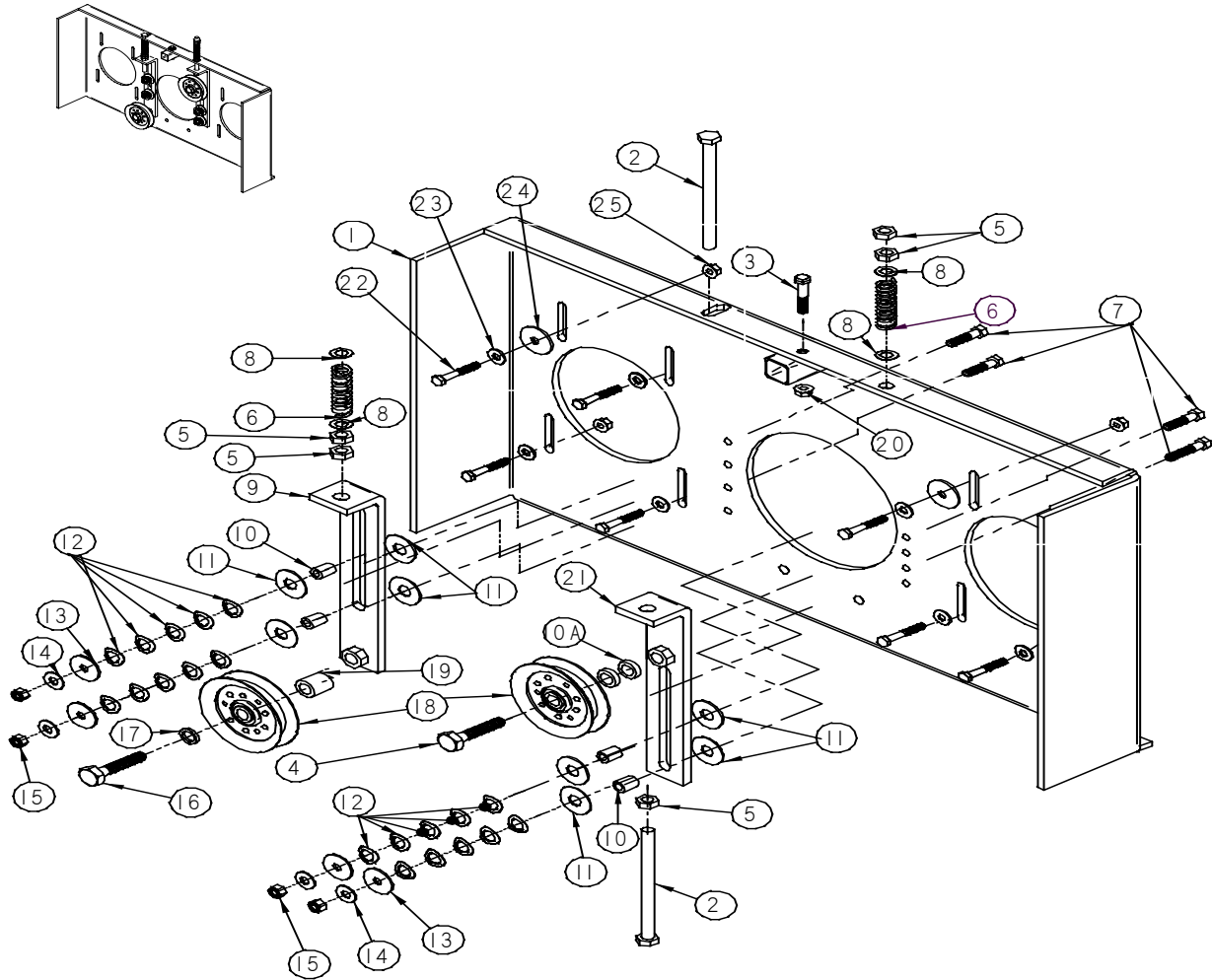

REF #	PART #	DESCRIPTION	QTY.
1	68076	Twin Engine Pod (Only)	1
2	B-202	1/2"-13x7" Bolt	2
3	B-124	3/8"-16x1 3/4" Bolt	1
4	B-188	5/8"-11x1 1/4" Bolt	1
5	N-111	1/2"-13 Jam Hex Nut	5
6	68280	Spring Engine Idler	2
7	B-124	3/8"-16x1 3/4" Bolt	4
8	W-110	1/2" Machined Bushing	4
9	68226-L	Idler Engine Bracket Left	1
10	61250	5/8"OD x .381ID x 3/4" Bushing	4
10A	W-119	1"OD.x 5/8"ID. Machine Bushing	2
11	W-140	5/8"ID.x 1 5/8"OD. Plastic Washer	8
12	W-149	5/8" Wafer Spring Washer	20

REF #	PART #	DESCRIPTION	QTY.
13	W-106	3/8" Fender Washer	4
14	W-104	3/8" Standard Flat washer	4
15	N-107	3/8"-16 Nylon Lock Nut	4
16	B-181	5/8"-11x2 1/2" Bolt	1
17	W-111	5/8" Lock Washer	1
18	30234	V-Idler Pulley	2
19	68109	1" OD x 1" Spacer	1
20	N-108	3/8"-16 Whiz Flange Nut	1
21	68226-R	Idler bracket Right	1
22	B-156	5/16"-18x2" Bolt	8
23	W-113	5/16" Flat Washer	8
24	W-107	3/8"ID.x 1 5/8" Beveled Washer	2
25	N-103-W	5/16"-18 Whiz Flange Nut	8

DIXIE CHOPPER

XXW4600 TWIN ENGINE POD

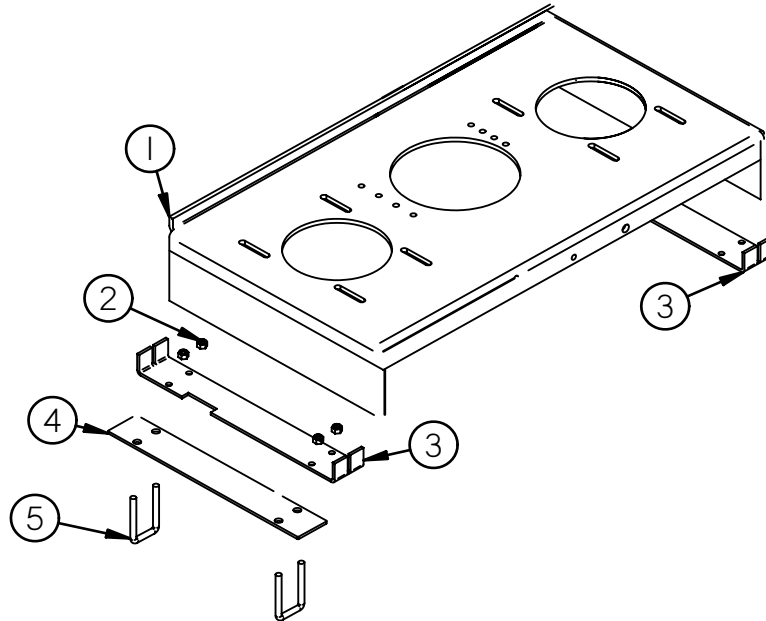

REF #	PART #	DESCRIPTION	QTY.
1	68075	Twin Engine Pod (Included - 1,3)	1
2	N-107	3/8"-16 Nyloc Lock Nut	8
3	68077	Base Frame Plate	2
4	600043	Spacer - Mounting Pod	2
5	B-244	1 3/8"W x 3 1/4"L U-Bolt	4

DIXIE CHOPPER

XXW4600 ENGINE OIL ROUTING

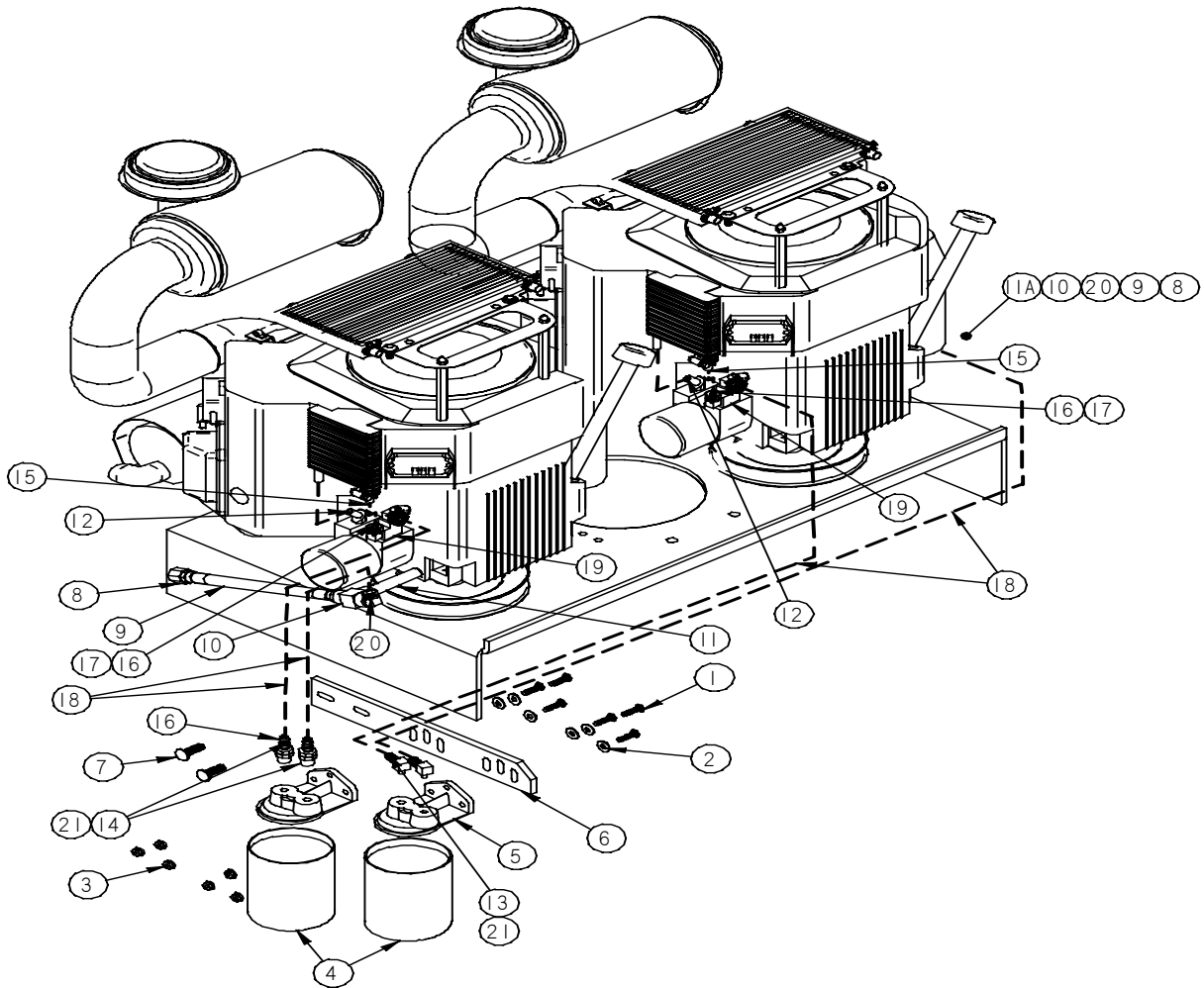

REF #	PART #	DESCRIPTION	QTY.
1	B-172	1/4"-20x1" Bolt	6
2	W-102	1/4" Flat Washer	6
3	N-102	1/4"-20 Whiz Flange Nut	6
4	60119	Amzoil Filter	2
5	60122	Amzoil Filter Mounting Base	2
6	68119	Mounting Bracket	1
7	B-135	3/8"-16x1" Carriage Bolt	2
8	10231	Oil Drain Pipe cap	2
9	68230	Oil Drain Hose	2
10	60102	3/8" T-Union Fitting	2
11	10230	3/8"x4" Pipe Nipple	1

REF #	PART #	DESCRIPTION	QTY.
11A	72230	3/8"x3" Pipe Nipple	1
12	Kohler No.	45 Deg.elb-1/4"mpx-.3/8" barb	2
13	60113	1/8"x3/8" 90 Deg. Fitting	2
14	60114	1/8"x3/8" Straight Fitting	2
15	68231	#4 Clamp	2
16	67013	Spring Clamp (Green)	10
17	67019	Hose Barb Brass	4
18	60109	3/8" Black Hose	Ft./
19	67022	1/4" Street Tee	2
20	87113	3/8" Male Pipe 3/8" Barb Straight	2
21	60116	3/8" Swivel x 3/8" Barb	4

DIXIE CHOPPER

23Hp KOHLER ENGINE

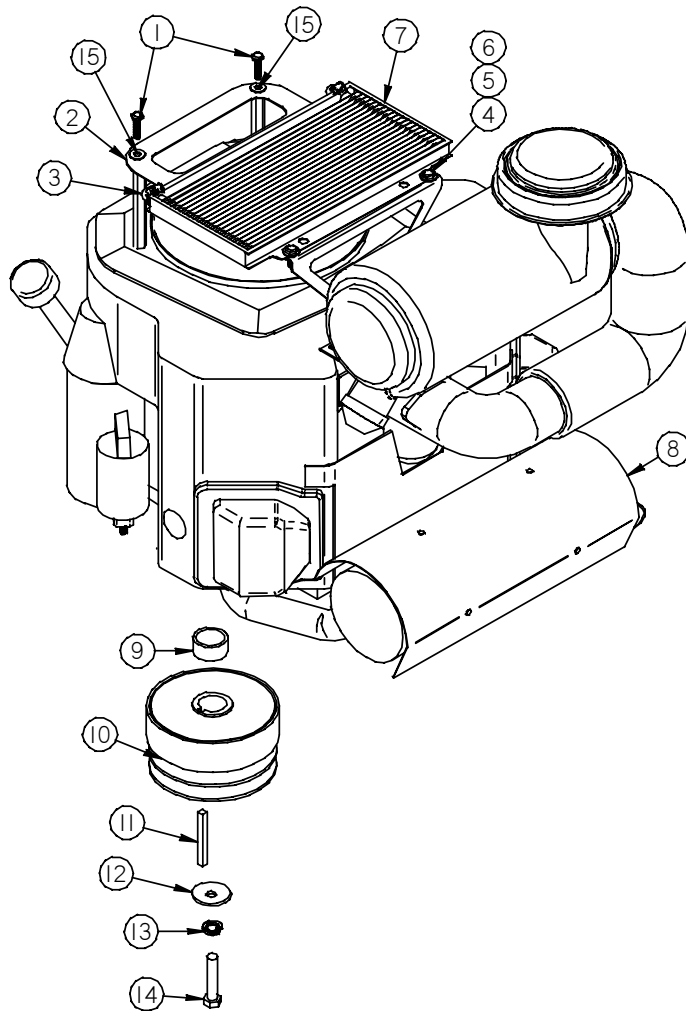

REF. #	PART #	DESCRIPTION	QTY.	REF #	PART#	DESCRIPTION	QTY.
1	B-103	1/4"-20x1/2" Bolt	2	8	600011	Muffler - 23Hp Kohler	2
2	400017	Bracket - Kohler Oil Cooler	2	9	68306	Spacer	2
3	600016	Bolt - 1/2"x3 1/2" Hex Kohler Oil Cooler	4	10	68300	Clutch Pulley	2
4	B-101	1/4"-20x1/2" Bolt	8	11	K-100	1/4"x2 1/2" Key Stock	2
5	W-102	1/4" Flat Washer	8	12	W-144	7/16" Stainless Belleville Washer	2
6	N-102	1/4"-20 Whiz Flange Nut	8	13	W-108	7/16" Lock Washer	2
7	60103-L	Oil Cooler	2	14	B-199	7/16"-20x2" Hex Head Bolt	2
				15	W-153	1/4" Stainless Washer	2

DIXIE CHOPPER

KOHLER 28Hp EFI ENGINE

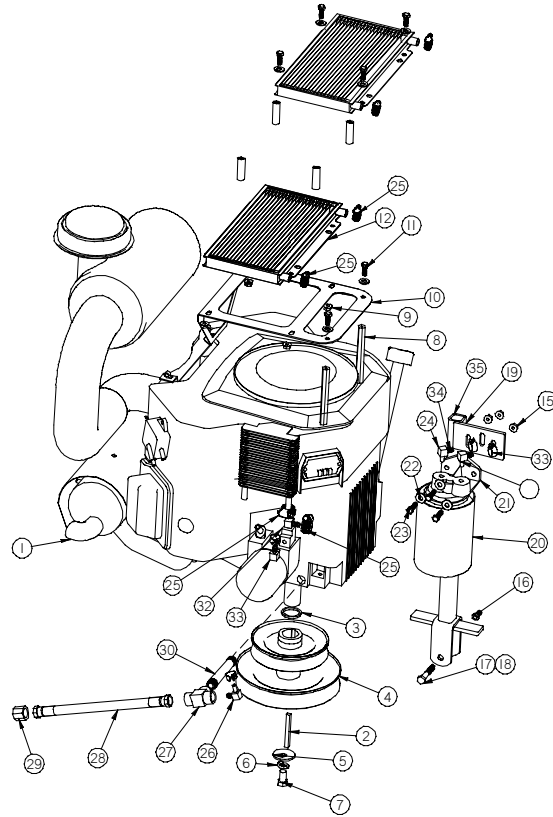

REF #	PART #	DESCRIPTION	QTY.
1	600018	Muffler - Kohler 26Hp EFI	1
2	K-100	1/4"x2 1/2" Key Stock	1
3	W-145	1-1/8" x 1-3/4" Washer	1
4	9907500X600D	Split Pulley 5" x 6"x1 1/8" Bore	1
5	W-144	7/16" Belleville Washer	1
6	W-108	7/16" Lock Washer	1
7	B-114	7/16"-20x3/4" Bolt	1
8	600016	Bolt - 1/2" x 3 1/2" Hex Kohler Oil	2
9	N-102	1/4"-20 Whiz Flange Nut	4
10	400017	Bracket - kohler Oil Cooler	1
11	B-103	1/4"-20x1/2" Bolt	2
12	60103-L	Oil Cooler	2
13	W-102	1/4" Flat Washer	4
14	B-267	1/4"- 20 x 2 1/4" Bolt	4
15	N-102	1/4"-20" Whiz Flange Nut	7
16	N-107	3/8"-16 Nyloc Nut	1
17	B-165	3/8"-16x2" Bolt	1
18	W-104	3/8" Standard Flat Washer	1

REF #	PART #	DESCRIPTION	QTY.
19	400025	Amsoil Filter Mount	1
20	60119	Amsoil Filter	1
21	60122	Amsoil Filter Head	1
22	W-102	1/4" Washer	3
23	B-172	1/4"-20x1" Bolt	3
24	60113	1/8"x3/8" 90Deg. Fitting	2
25	68231	#4 Hose Clamp	6
26	60125	90 3/8 pipe Thread 3/8 Barb	1
27	60102	3/8" Black Pipe Tee	1
28	68230	Oil Drain Hose Assembly	1
29	10231	3/8" Steel Pipe Cap	1
30	10230	4" Pipe Nipple	1
31	67019	Hose Barb Brass	1
32	67022	1/4" Street Tee	1
33	67013	Spring Clamp Green	3
34	60116	3/8" Swivel to 3/8" Barb	2
35	68142	Plug - Plastic	1
36	200020	Space - Cooler	4
37	W-153	1/4" Stainless Steel Washer	2

DIXIE CHOPPER

ENGINE - 30Hp GENERAC

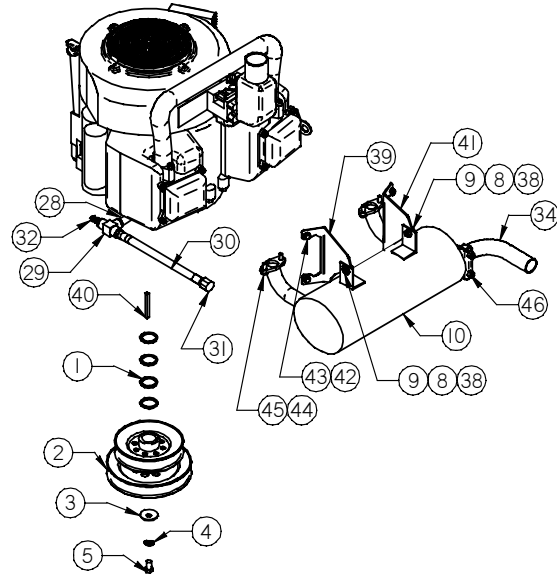
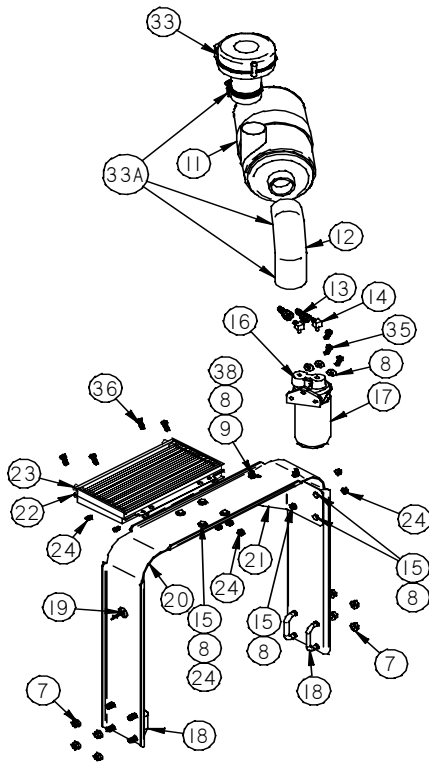

REF #	PART #	DESCRIPTION	QTY.
1	W-178	1 1/4"ID x 1 7/8"OD x 1/8" Thick Washer	4
2	600033	Pulley - 5x6x1.25 Engine	1
3	W-144	7/16" Stainless Belleville Washer	1
4	W-108	7/16" Lock Washer	1
5	B-164	7/16"x1 3/4" Bolt	1
7	N-107	3/8"-16 Nylon Locknut	8
8	W-113	5/16" Flat Washer	15
9	B-107	5/16"-18x3/4" Bolt	4
10	600032	Muffler - Generac	1
	0C4138	Gasket - 30Hp & Generac Muffler	2
	B-276	M8 x 20-1.25 Socket Head Cap Screw	
	W-163	M8 mm Lock Washer	
11	600036	Canister - Air for Generac Engine	1
	600046	Filter - Enginaire Primary Air	1
	600047	Filter - Enginaire Secondary Air	1
12	600039	Hose - Air Cleaner Hose For Generac 30Hp	1
13	60116	3/8" Swivel to 3/8" Barb	2
14	60113	1/8"x3/8" 90Deg. Fitting	2
15	B-102	1/4"-20x3/4" Bolt	8
16	60122	Bracket - Filter Mount Amsoil	1
17	60119	Filter - 1 Micron Amsoil	1
18	B-247	3/8"-16x2 3/8"W x 2"L Sq. U-Bolt	4
19	60117	Oil Shut Down Horn	1
20	400062	Bracket - Main Mounting Bracket	1

REF #	PART #	DESCRIPTION	QTY.
21	400061	Bracket - Amsoil Generac	1
22	400059	Bracket - Oil Cooler Generac	1
23	60103-L	New Short Oil Cooler	2
24	N-102	1/4"-20 Whiz Flange Nut	15
28	72230	3/8" Black Pipe Nipple 3" Long	1
29	60102	3/8" Black Pipe Tee	1
30	68230	Oil Drain Hose Assembly	1
31	10231	3/8" Steel Pipe Cap	1
32	87113	3/8" Male Pipe 3/8" Barb - Straight	1
33	90115	Turbo Pre-cleaner	1
33A	90125	2" Worm Clamp	3
34	600059	Tailpipe - Generac Muffler	1
35	B-172	1/4"x20x1" Bolt	3
36	B-101	1/4"x20x1/2" Bolt	4
38	N-103-W	5/16"-18 Whiz Flange Nut	2
39	600057	Bracket - LH Muffler	1
40	K-100	1/4" Key	1
41	600058	Bracket - RH Muffler	1
42	B-269	M6-16x1.00 Bolt	4
43	W-179	M6 Lockwasher	4
44	B-276	M8-20x1.25 Bolt	4
45	W-163	M8 Lockwasher	4
46	600060	Clamp - Generac Muffler Tailpipe	1

DIXIE CHOPPER

ENGINE - 30Hp GENERAC SERIAL NUMBER 3041605 AND AFTER

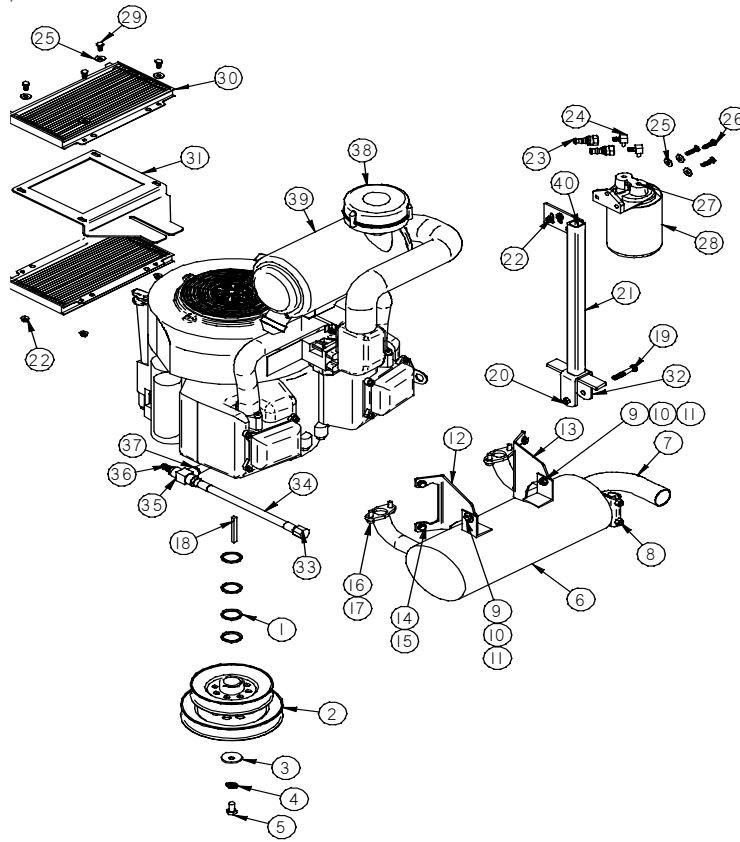

REF #	PART #	DESCRIPTION	QTY.
1	W-178	1 1/4" ID x 1 7/8" OD x 1/8" Thick	4
2	600033	Pulley - 5x6x1 1/4" Engine	1
3	W-144	7/16" Stainless Belleville Washer	1
4	W-108	7/16" Lock Washer	1
5	B-164	7/16" x 1 3/4" Bolt	1
6	600032	Muffler - Generac	1
	OC4138	Gasket - 30Hp Generac Muffler	2
7	600059	Tailpipe - Generac Muffler	1
8	600060	Clamp - Generac Muffler Tailpipe	1
9	B-107	5/16"-18x3/4" Bolt	2
10	W-113	5/16" Flat Washer	2
11	N-103-W	5/16"-18 Whiz Flange Nut	2
12	600057	Bracket - LH Muffler	1
13	600058	Bracket - RH Muffler	1
14	W-179	M6 Lock Washer	4
15	045761A	Stud - M8 - 1.25 x 10MM	4
16	052858	Nut - Lock Flange M8 - 1.25	4
17	B-276	M8-20x1 1/4" Bolt	4
18	K-100	1/4" Key	1
19	B-165	3/8"-16x2" Bolt	1
20	N-107	3/8"-16 Nyloc Nut	1

REF #	PART #	DESCRIPTION	QTY.
21	400025	Amsoil Filter Mount	1
22	N-102	1/4"-20 Whiz Flange Nut	7
23	60116	3/8" Swivel to 3/8" Barb	2
24	60113	1/8" x 3/8" 90 Degree Fitting	2
25	W-102	1/4" Washer	7
26	B-172	1/4"-20x1" Bolt	3
27	60112	Amsoil Filter Head	1
28	60119	Amsoil Filter	1
29	B-101	1/4"-20x1/2" Bolt	4
30	60103-L	Oil Cooler	2
31	400105	Bracket - Oil Cooler Generac	1
32	W-104	3/8" Standard Flat Washer	1
33	10231	3/8" Steel Pipe Cap	1
34	68230	Oil Drain Hose Assembly	1
35	60102	3/8" Black Pipe Tee	1
36	87113	3/8" Male Pipe 3/8" Barb - Straight	1
37	72230	3/8" Black Pipe Nipple 3" Long	1
38	90115	Turbo Pre-cleaner	1
39	0E3655	Canister - Donaldson Air Cleaner	1
	0E3557	Primary Element Donaldson Air Cleaner	1
	0E3656	Secondary Element Donaldson Air Cleaner	1
40	68142	Plastic Plug 1x1	1

DIXIE CHOPPER

30Hp GENERAC ENGINE OIL ROUTING

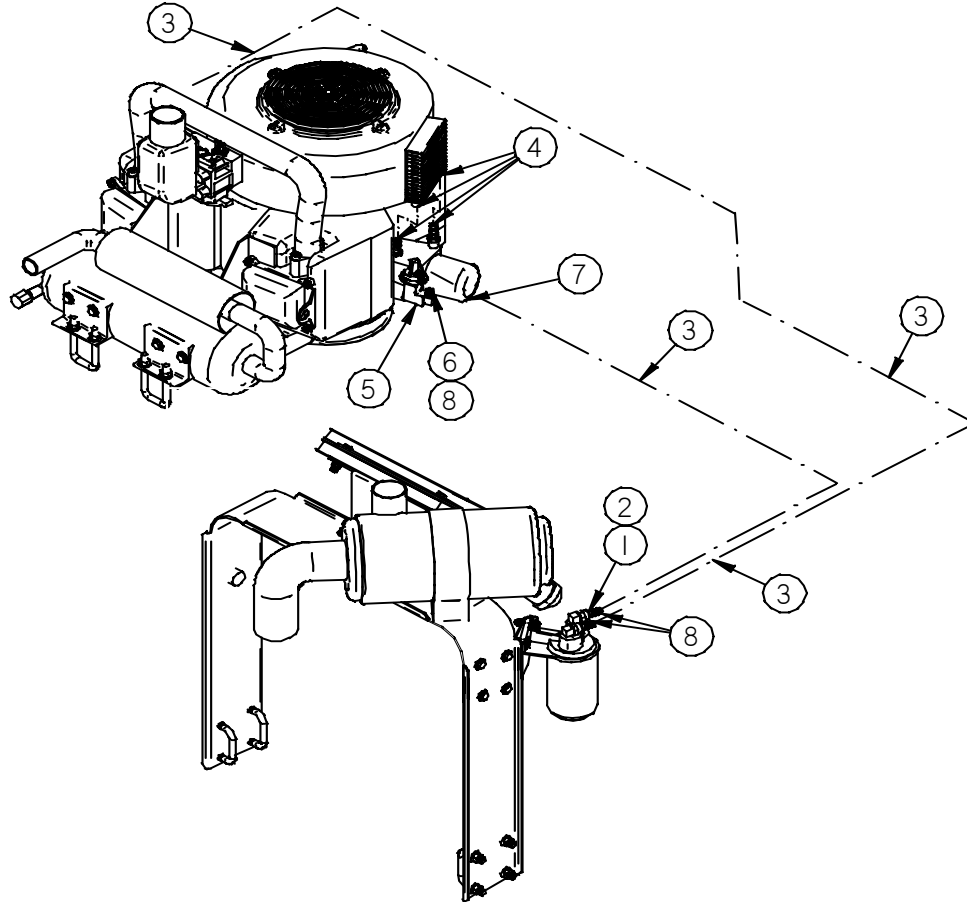

REF #	PART #	DESCRIPTION	QTY.
1	60113	1/8" x 3/8" 90Deg. Fitting	2
2	60116	3/8" Swivel to 3/8" Barb	2
3	60109	3/8" Line	ft/
4	68231	#4 Worm Clamps	4
5	67022	1/4 Street Tee	1
6	67019	Hose Barb Brass	1
7	070185	Oil Filter	1
8	67013	Green Clamps	3
	0D6313	Fuel Filter	1
	NGK-FR4	Generac Spark Plug	2
	0E4271	Starter	1

DIXIE CHOPPER

30Hp GENERAC ENGINE OIL ROUTING SERIAL NUMBER 3041605 AND AFTER

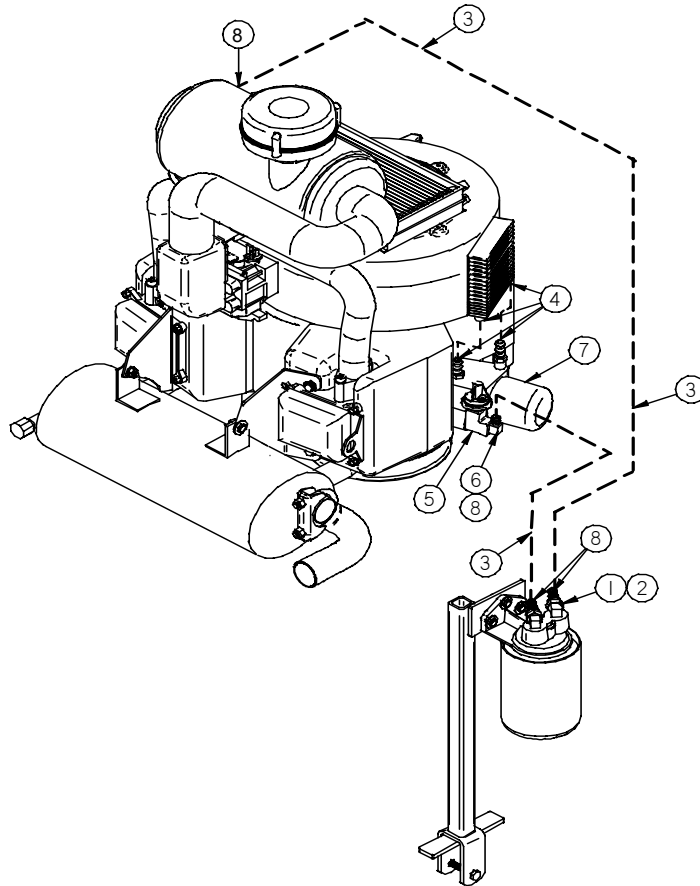

REF #	PART #	DESCRIPTION	QTY.
1	60113	1/8" x 3/8" 90Deg. Fitting	2
2	60116	3/8" Swivel to 3/8" Barb	2
3	60109	3/8" Line	ft/
4	68231	#4 Worm Clamps	4
5	67022	1/4 Street Tee	1
6	67019	Hose Barb Brass	1
7	070185	Oil Filter	1
8	67013	Green Clamps	4
	0D6313	Fuel Filter	1
	NGK-FR4	Generac Spark Plug	2
	0E4271	Starter	1

DIXIE CHOPPER

KOHLER 23Hp ELECTRICAL DIAGRAM

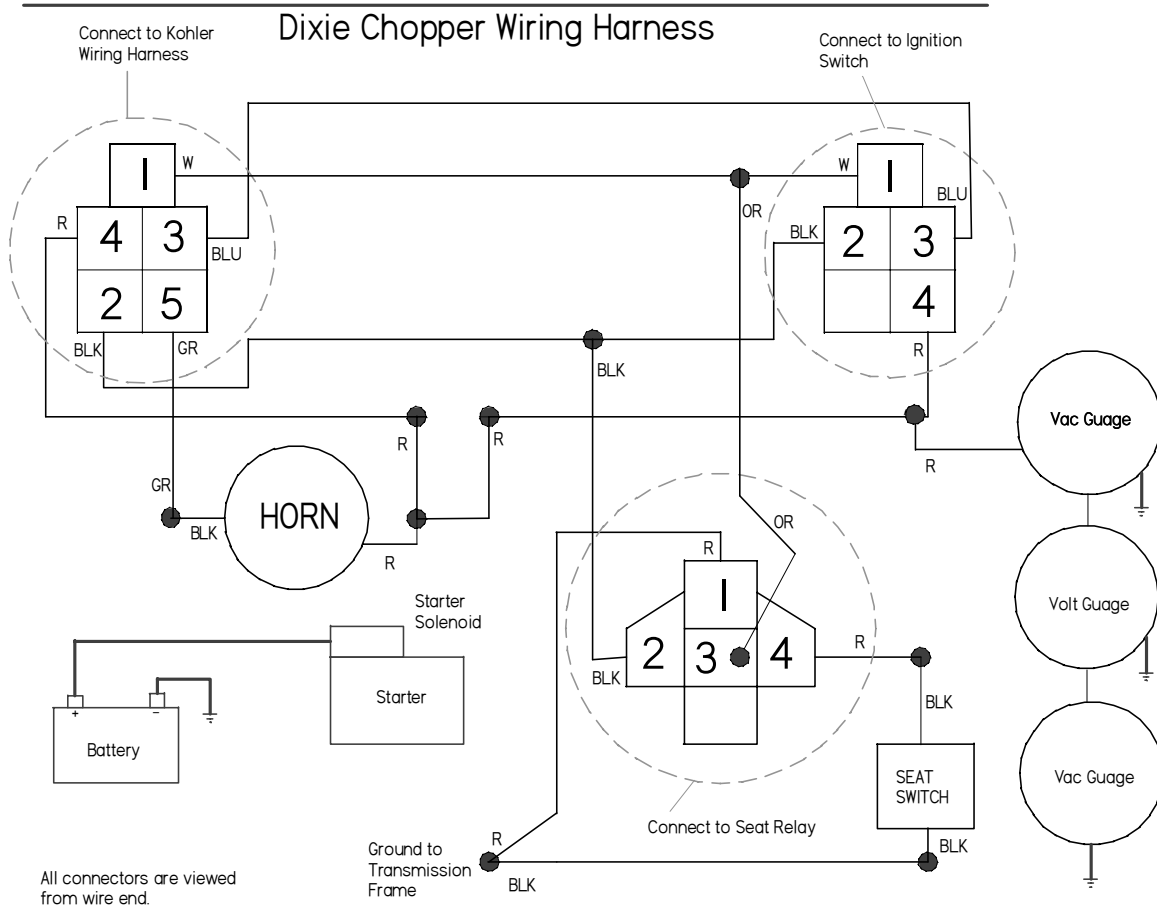
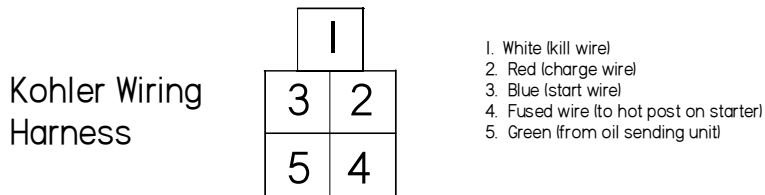

REF #	PART #	DESCRIPTION	QTY.
1	65526	Twin Harness	2
2	20245	Ignition Switch	2
3	20246-T	Hour Meter/Tach	2
4	68247	Tach Bracket	2
5	N/A	Battery	1
6	20228	Battery Strap	1
7	400065	Battery Box	1
8	20225-B	Red Rubber Boot	1
9	20227-72	Battery Cable Positive (72")	1
10	20226-B	Battery Cable Ground (12")	1

REF #	PART #	DESCRIPTION	QTY.
11	20227-36	36" Red Battrey Cable	1
12	60117	Horn(Clamp F/Horn P#C-113)	2
13	40229	Mercury Switch	2
14	C-112	Clamp for Mercury Switch	2
15	65510	Seat Relay	2
16	97191	Seat Relay Pigtail	2
17	65509	Fuse	2
18	20254	Fuse Holder	2
19	68238	Vac Guage	2
20	68239	Volt Guage	1

DIXIE CHOPPER

KOHLER 28Hp EFI ELECTRICAL DIAGRAM

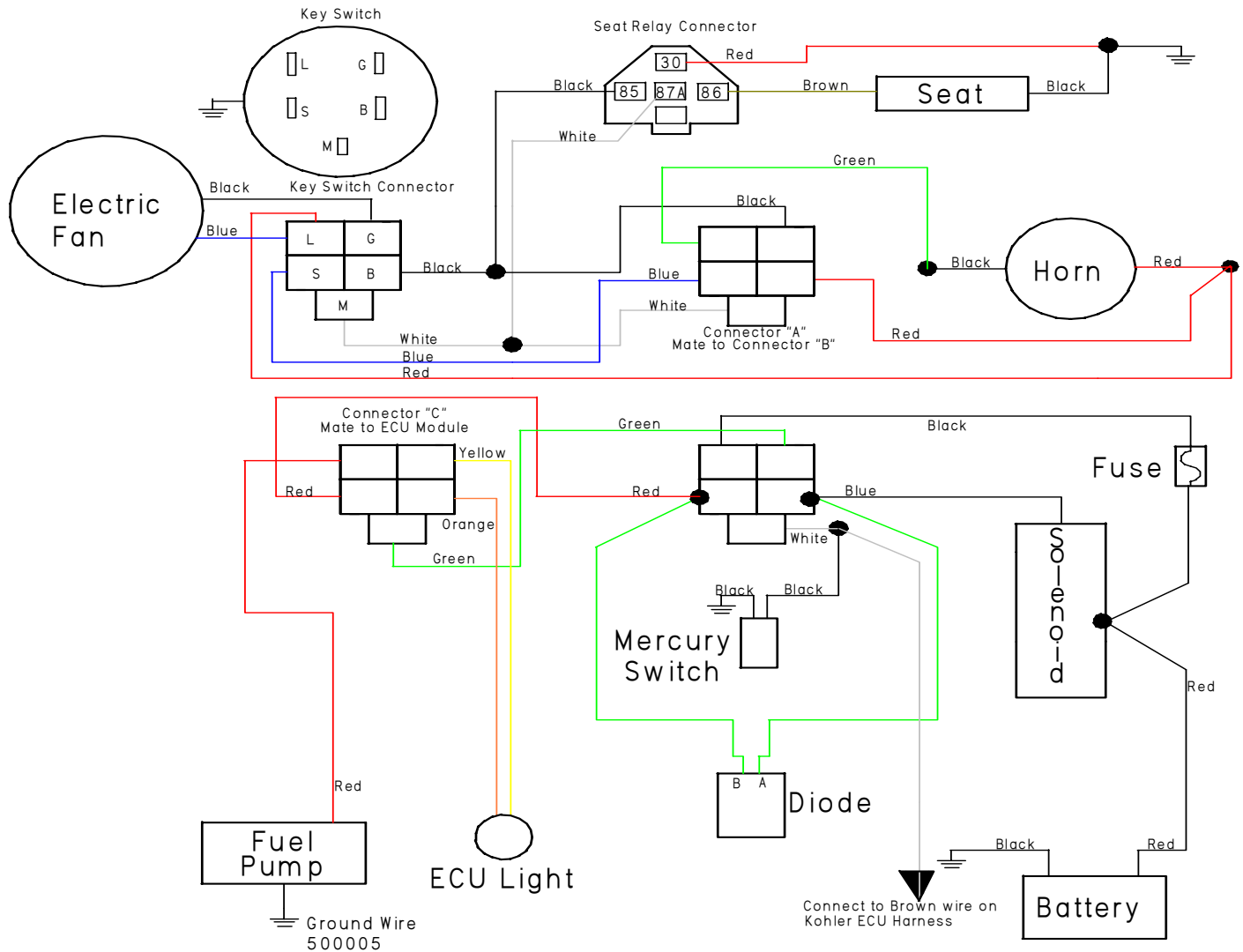

REF #	PART #	DESCRIPTION	QTY.
1	500002	Kohler EFI Wiring Harness	1
2	20245	Ignition Switch	1
3	20246-T	Hour Meter/Tach	1
4	68247	Tach Bracket	1
5	N/A	Battery	1
6	20228	Battery Strap	1
7	400065	Battery Box	1
8	20225-B	Red Rubber Boot	1
9	20227-72	Battery Cable Positive (72")	1
10	20226-B	Battery Cable Ground (12")	1

REF #	PART #	DESCRIPTION	QTY.
11	40229	Mercury Switch	1
12	C-112	Clamp for Mercury Switch	1
13	65510	Seat Relay	1
14	97191	Seat Relay Pigtail	1
15	65509	Fuse	1
16	20254	Fuse Holder	1
17	60117	Horn(Clamp F/Horn P#C-113)	1
18	500005	Ground Wire	1
19	500003	ECO Light	1
20	200043	Electrical Fan	1

DIXIE CHOPPER

GENERAC 30Hp ELECTRICAL DIAGRAM

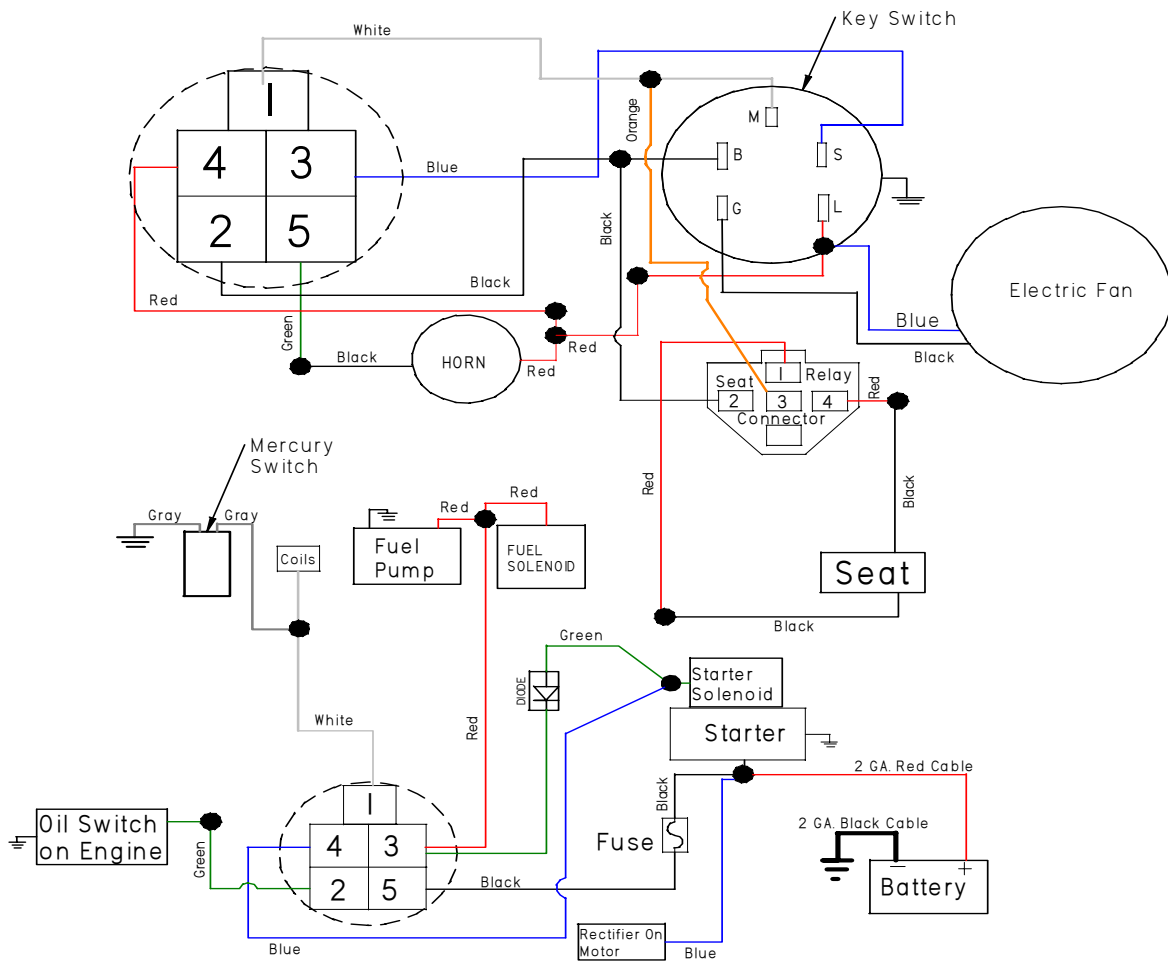

REF #	PART #	DESCRIPTION	QTY.	REF #	PART #	DESCRIPTION	QTY.
1	500004	Generac Wiring Harness	1	10	500010	Battery Boot (XT3000)	1
2	20245	Ignition Switch	1	11	40229	Mercury Switch	1
3	20246-T	Hour Meter/Tach	1	12	C-112	Clamp For Mercury Switch	1
4	68247	Tach Bracket	1	13	65510	Seat Relay	1
5	NA	Battery	1	14	600038	30-hp Generac Engine	1
6	400072	Battery Box (XT3000) Including Ref. #7	1	15	97191	Seat Relay Pigtail	1
7	400073	Battery Strap (XT3000)	1	16	65509	Fuse	1
8	500008	Battery 2Ga. Cable Positive 38" (XT3000)	1	17	20254	Fuse Holder	1
8	500008	Battery 2Ga. Cable Positive 38" (XT3000)	1	18	60117	Oil Horn	1
9	500009	Battery Cable Ground 46" (XT3000)	1	19	200043	Electrical Fan	1

DIXIE CHOPPER

NOTES

DIXIE CHOPPER

6302 E. County Road 100 North
Coatesville, IN. 46121
Phone 1-765-CHOPPER
www.dixiechopper.com

Dixie Chopper, Magic Circle, and the Magic Circle Atom Logo are all trademarks of Magic Circle Corporation and may not be reproduced without permission.

Printed In USA

Specifications and instructions subject to change without notice.

Print Date 3/01